

# ACT Tanks

## *Open Top Rectangle Containment Tanks*

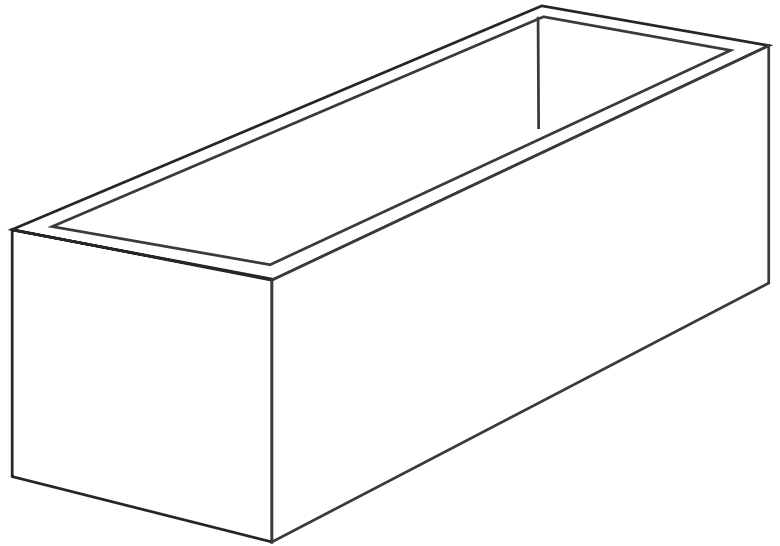

### **Key Features**

- Industrial Grade Polyethylene
- Easy Placement
- Space Saving Sizes
- Open Top Design
- Lower Shipping Cost
- Optional Accessories

### **Application**

Advantage Controls' ACT series of open top containment solution tanks provide a customer friendly system for stationary liquid containment.

ACT tanks open top rectangle design are a space saving option for containing smaller prepackaged solution tanks. Made from industrial grade polyethylene the ACT tanks cover a wide range of chemicals safely.

Advantage Control's ACT tanks are a safe low cost solution for secondary chemical containment to meet today's environmentally friendly storage concerns.

## Models

**ACT-25** 20 gallon tank.  
**ACT-27** 27 gallon tank.

## Options

**B** 1/2" FNPT bulkhead fitting for drain

## Specifications

### Material of Construction

All tanks are made of UV stabilized linear polyethylene with an average wall thickness of 1/6 inch.

### Shipping Weight

ACT-25 ..... 15 lbs  
ACT-27 ..... 15 lbs

### Dimensions

	Length	Width	Height
ACT-25	39.0"	15.0"	12.0"
ACT-27	24.0"	24.0"	12.0"

---

**Get the Advantage**