

ATS Tanks

Tank and Pump Mounting System

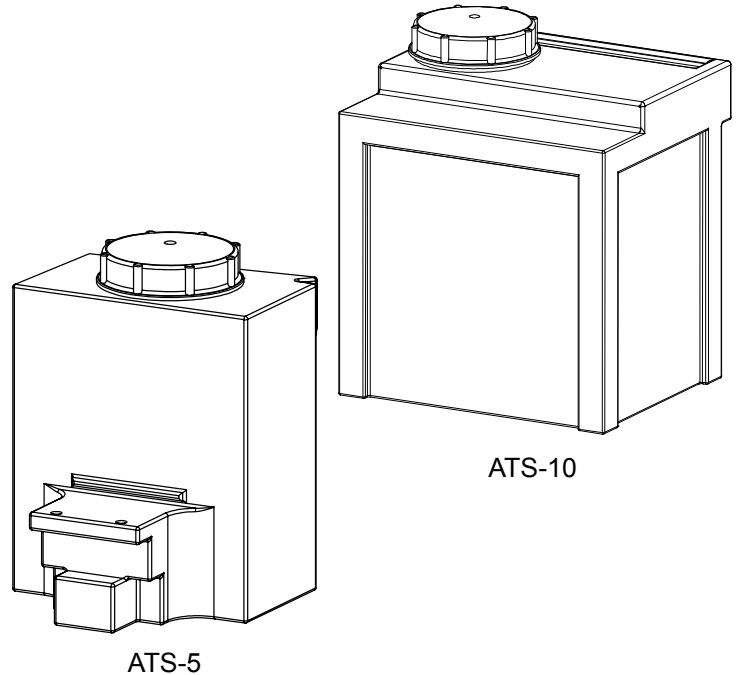

Key Features

- Industrial Grade Polyethylene
- 5-10 Gallon Capacity
- Convenient Pump Mounting
- Wall Mountable
- Heavy Duty Threaded Lid
- Spring Loaded Vent
- Flooded Suction
- Incremental Markings (ATS-5)
- Large Refill Opening

Application

The ATS molded tank system provides an integrated chemical metering pump mounting bracket and solution tank in one unit.

ATS tanks have a large, heavy duty, vented and threaded lid for easy refill. Optional 1/2 FNPT weldlets offer secure mounting of pump suction and return lines plus a convenient drain point.

Designed for wall mounting or free standing installations, the ATS tank system provides a safe professional installation of chemical feed systems.

Model

- ATS-5** 5 gallon tank with lid and molded-in pump shelf
- ATS-10** 10 gallon tank with lid

OPTIONS

- B1** Bulkhead fitting Kynar mounted, 3/8" tubing
- B2** Bulkhead fitting Kynar mounted, 1/4" tubing
- C** Controller bracket instead of pump on ATS-5
- D1** 3/8" Bulkhead fitting with PVC shut off w/ Buna seal
- D2** 1/4" Bulkhead fitting with PVC shut off w/ Buna seal
- F** Flat top with 2" bung
- L** 2" bung for level wand
- M** Premount pump (ordered separate)
- P** Non Advantage pump adapter plate
- P1** Pump mount plate for top of ATS-10
- S** MNPT drain valve
- T** Pump priming tube return fitting
- V** 1/4" solenoid valve with Y-strainer prewired 8' cord
- W** Stainless Steel wall mounting bracket

INSTALLATION

The optional wall mounting bracket (W) provides a V shaped stainless steel bracket and hardware for mounting to a wall. The tank then slips into the bracket.

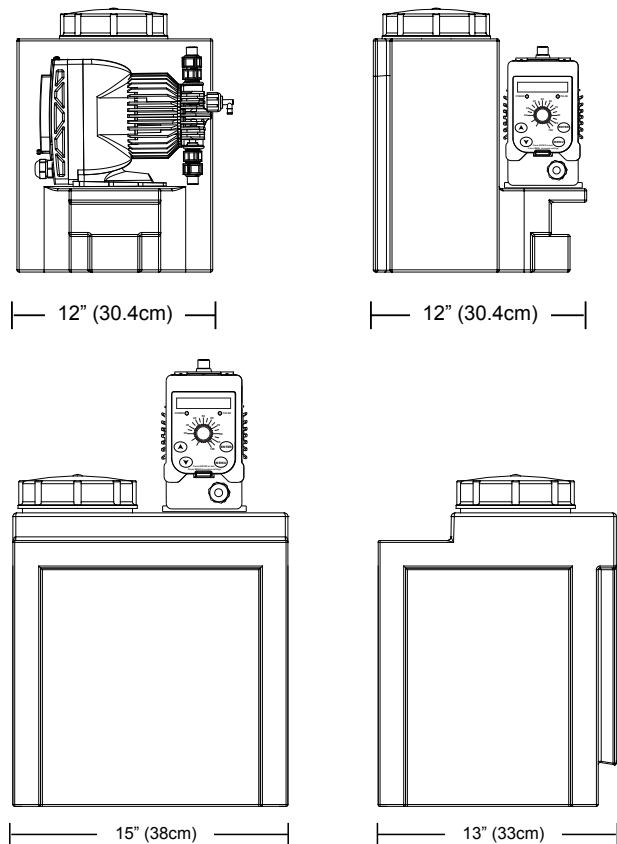

Specifications

Construction

The tank is made of linear polyethylene (LLDPE) which is UV stabilized and FDA approved. It has an average wall thickness of 1/4 inch. The lid opening is 5 1/4" I.D.

- Lid** Polypropylene
- Bulkhead (opt.)** Kynar
- Shut-off (opt.)** PVC

Dimensions

ATS-5 (tank only):	ATS-10 (tank only):
W 12" (30.4cm)	W 15" (38cm)
H 19.75" (50.1cm)	H 17.875" (45.4cm)
D 12" (30.4cm)	D 13" (33cm)

Shipping Weight

- ATS-5**
- Tank only 10 lbs
- Tank and Wall Bracket 11.5 lbs

- ATS-10**
- Tank only 8 lbs
- Tank and Wall Bracket 9.5 lbs

Get the Advantage



4700 Harold Abitz Dr
 Muskogee, OK 74403
 800-743-7431 phone
 888-686-6212 fax
www.advantagecontrols.com