

# DCT Tanks

## *Double Wall Containment Tanks*



## Key Features

- Industrial Grade Polyethylene
- Convenient Pump Mount
- Removable Lid
- Accessory Mount Areas
- Large Refill Opening
- Inner Stackable Design
- Lower Shipping Cost
- Optional Accessories

## Application

Advantage Controls' DCT series of double wall containment solution tanks provide an environmentally friendly system for stationary liquid containment.

DCT tanks have a large, heavy duty lid that includes a multiple metering pump mounting area with spill containment, a large fill opening and four tank accessory mounting points for optional mixers, level sensors and quick fill connection.

Advantage Control's DCT tanks also give you the advantage of lower shipping cost since the lid is removable allowing multiple tanks of the same size to be inner stacked. Once on site simply put the inner tank inside the outer tank and snap on the lid.

## Models

- DCT-30** 34 gallon inner tank with a 40 gallon containment tank.
- DCT-55** 58 gallon inner tank with a 70 gallon containment tank.

## Options

- C** 2" FNPT lid accessory mounting points  
**D** 5" pop-out plug for pouring in through lid  
**F** 3/4" PPL fill connection installed in lid  
**F1** 1" PPL fill connection installed in lid  
**H** Heavy duty wall on inner tank  
**L** Level indicator-SST  
**M** Flange mount 1/20 HP mixer  
**M1** Bung mount 1/20 HP mixer  
**P** Non Advantage Controls pump mount adapter  
**R** Rigid suction tube  
**S** Suction tube holes predrilled for Advantage pumps  
**T** Transfer pump with tubing  
**T1** Transfer pump mounting bracket only  
**U** Assembled and individually boxed  
**W** Level wand with float switch

**NOTE:** When ordering C and/or S, just list the letter once followed by each hole placement number desired. i.e. C134. Suction holes are 1.125"

## Lid Details

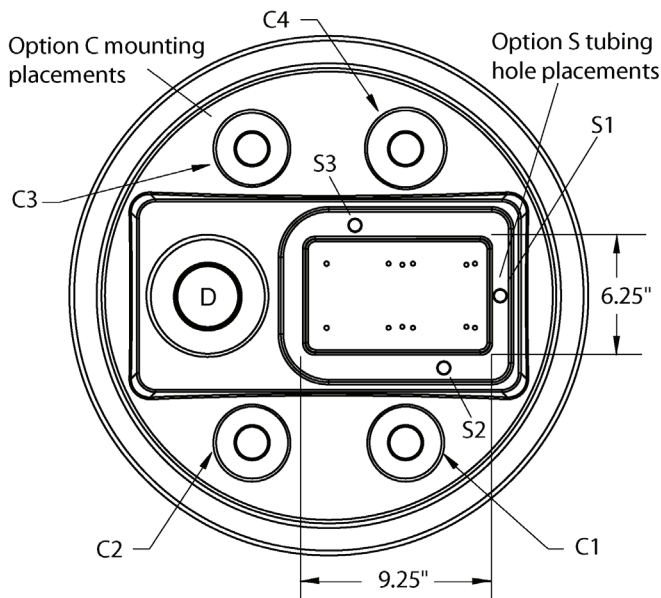

## Specifications

### Material of Construction

All tanks are made of UV stabilized linear polyethylene with an average wall thickness of 1/6 inch.

### Shipping Weight

DCT-30.....	35 lbs
DCT-55.....	45 lbs

Dimensions	A	B	C	D	E
DCT-30	23.7"	32.8"	3.0"	30.0"	19.2"
DCT-55	27.3"	44.3"	5.2"	39.0"	22.0"

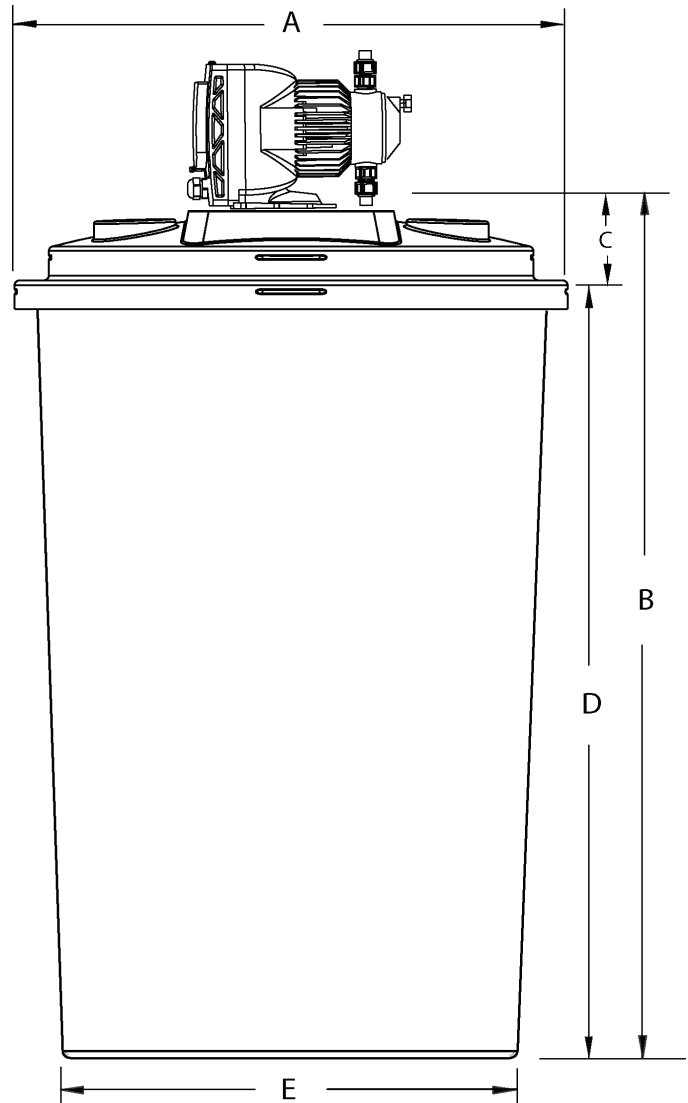

**Get the Advantage**



4700 Harold Abitz Dr  
 Muskogee, OK 74403  
 800-743-7431 phone  
 888-686-6212 fax  
 www.advantagecontrols.com