

PUMP-BOX

Plastic Enclosure

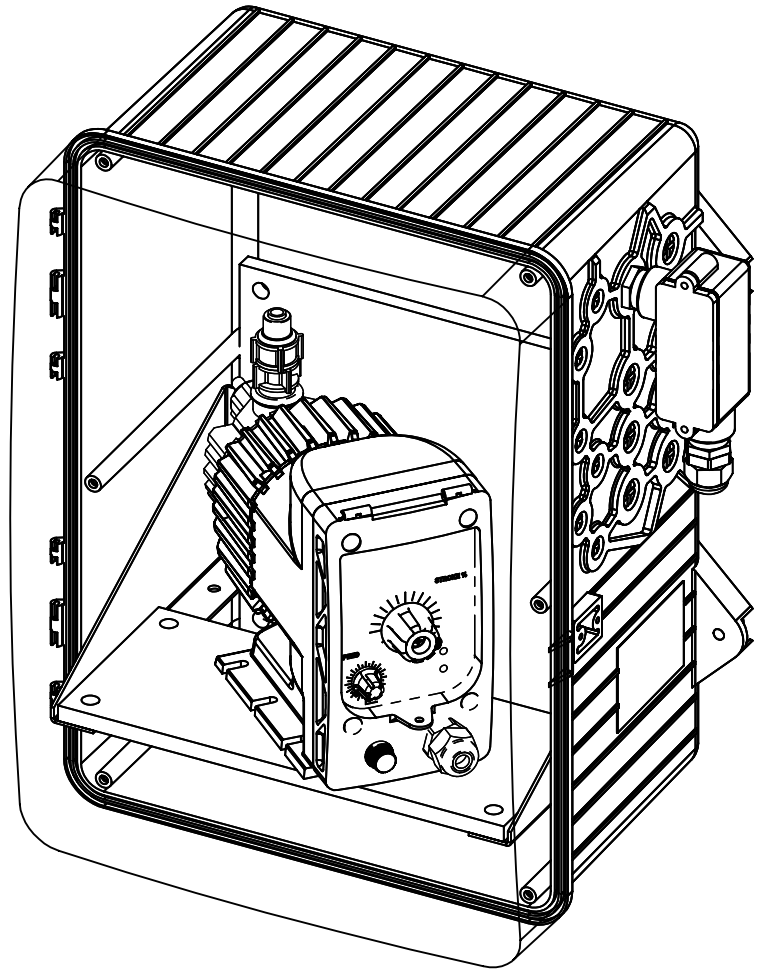

Key Features:

- Rugged ABS construction
- Inlet & outlet tubing
- Added weather protection
- Clear, lockable cover
- Prevents tampering
- Optional leak sensor

Application

The Advantage PUMP-BOX provides an affordable option to safely enclose small chemical metering pumps.

The PUMP-BOX is an ABS plastic enclosure with a clear or black hinged cover including a stainless steel lockable latch, liquid tights for inlet and outlet tubing and a pre-wired electrical connection.

An optional leak detection fitting and sensor can provide a dry contact output to web based MegaTron controllers for remote notification of a pump leak.

Build a Model

Model: PUMP-BOX

Options

- A** = No external male power cord
- B** = Black cover
- L** = Leak detection sensor assembly
- M** = Mount separately ordered pump in box
- M1** = Mount customer supplied pump in box

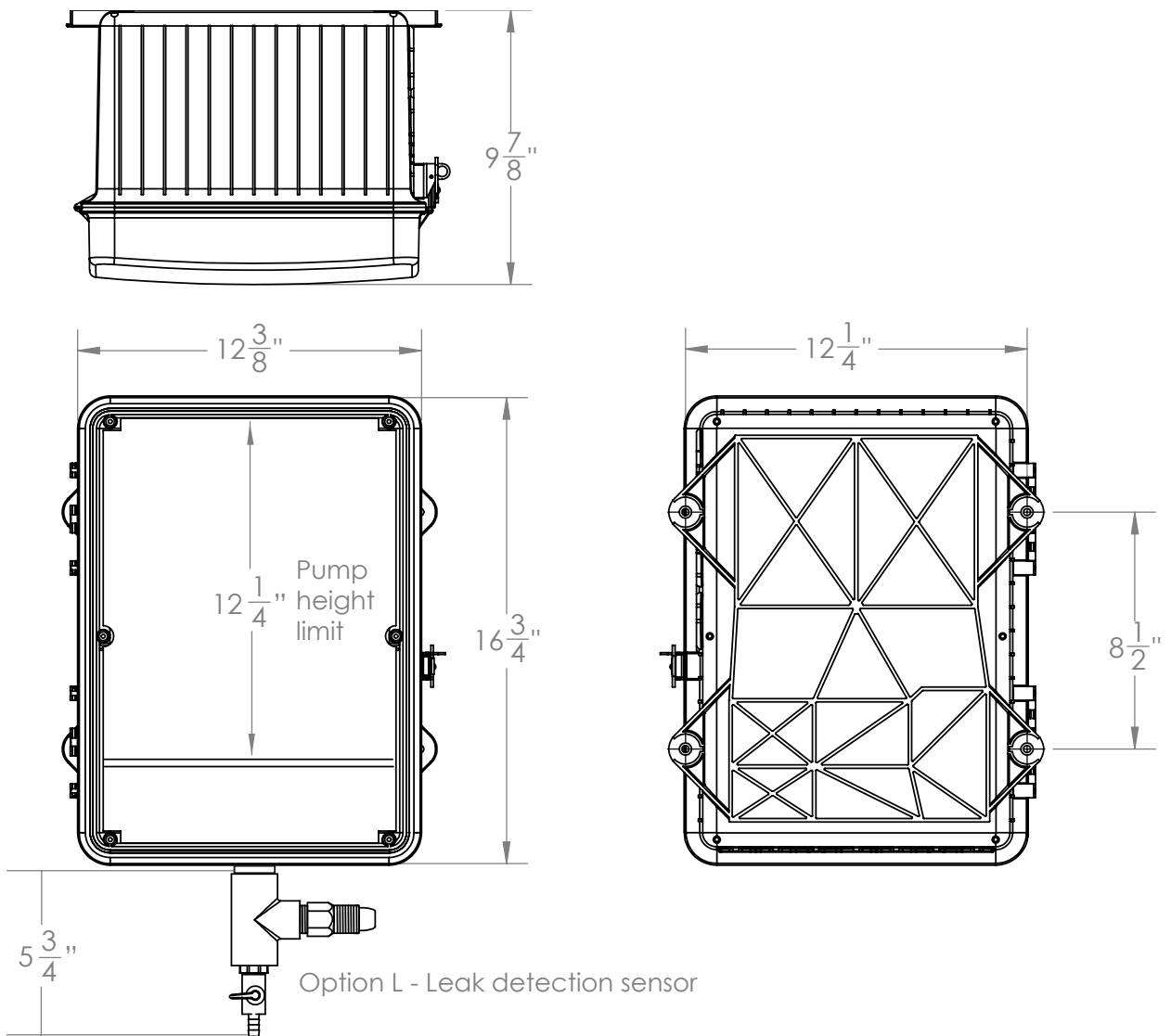

Get the Advantage



4700 Harold Abitz Dr
Muskogee, OK 74403
918-686-6211 phone
888-686-6212 fax
www.advantagecontrols.com