

PUMP-BRACKET

Universal Pump Mounting Bracket

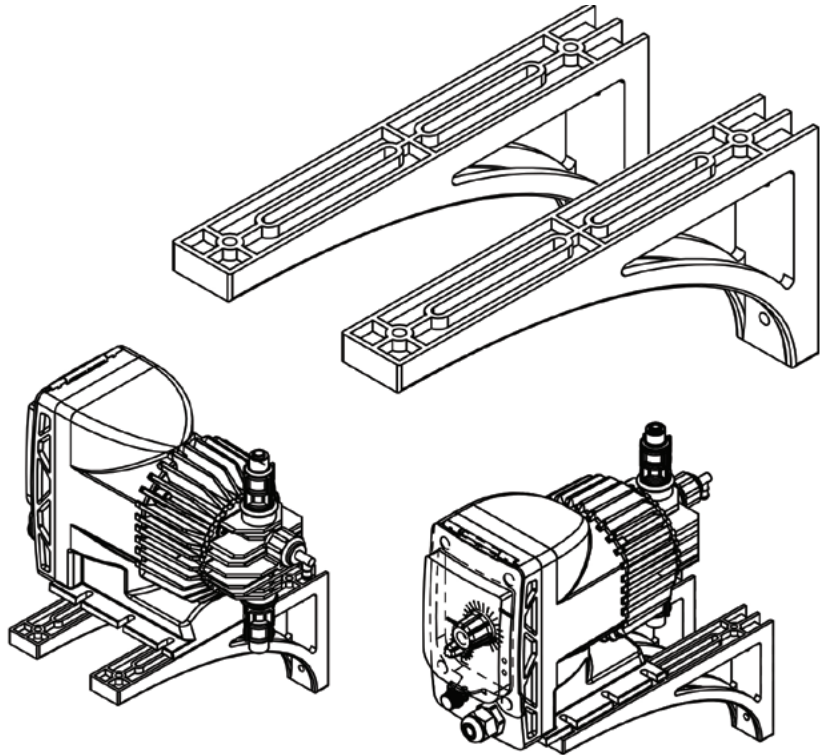

Key Features:

- Saves Time
- Saves Money
- Simplifies Installations
- Professional Appearance
- Chemical Resistant
- Keeps Pump Secure
- Includes Mounting Hardware

Description

Give all of your pumps a secure and professional installation. The unique dual mounting slot design with two individual brackets allows the PUMP-BRACKET to work with most brands of pumps.

Constructed of chemical resistant industrial thermoplastic and provided with mounting hardware, the sturdy bracket insures your metering pump will stay safely and securely installed.

Bracket Dimensions

Two individual brackets are included with the PUMP-BRACKET.
Individual dimensions are:

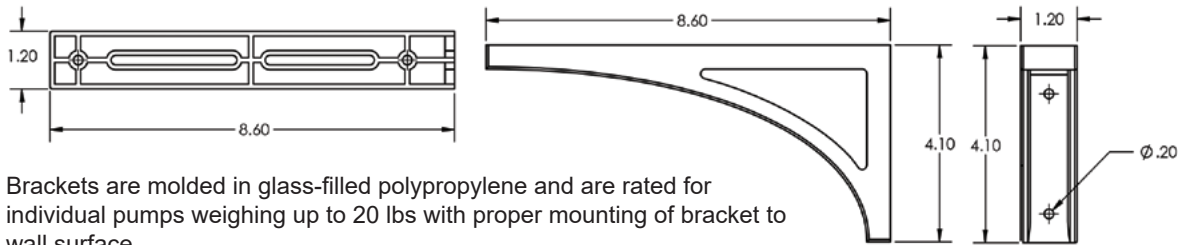

Brackets are molded in glass-filled polypropylene and are rated for individual pumps weighing up to 20 lbs with proper mounting of bracket to wall surface.

Pump Mounting Shelves

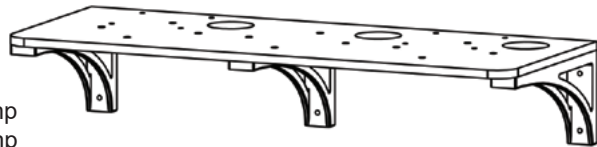

Preassembled pump mounting shelves are also available using pump brackets and a polyethylene panel with suction tubing holes. All pump mount shelves are 9.25" deep (23.50 cm).

Models

- PMS-02**..... Two pumps shelf, 15" long (38.1 cm)
- PMS-03**..... Three pumps shelf, 24" long (60.96 cm)
- PMS-04**..... Four pumps shelf, 32" long (81.28)

Options

- B** Mounts shelf to 18" tall poly back board
- N** No mounting holes
- P1** Pulsafeeder A+ pump mounting pattern (only available with S option)
- S** Stainless steel mounting brackets on PMS
- U** Replaces white poly with 1/2" blue poly

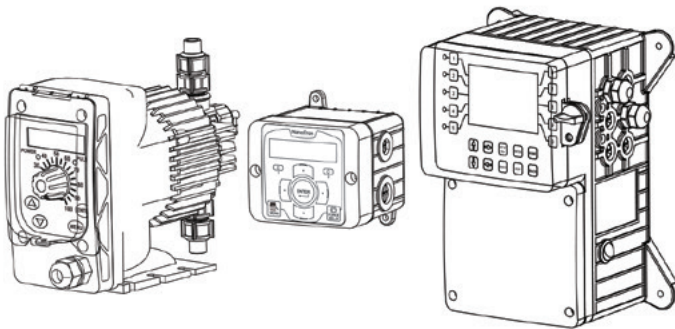

Advantage Controls offers a complete line of water treatment controls and feed equipment. We look forward to helping you *Get the Advantage* on all of your water treatment equipment needs.

Get the Advantage

