

NanoTron P/R

P(pH) / R(ORP)

Installation

Maintenance

Repair

Manual

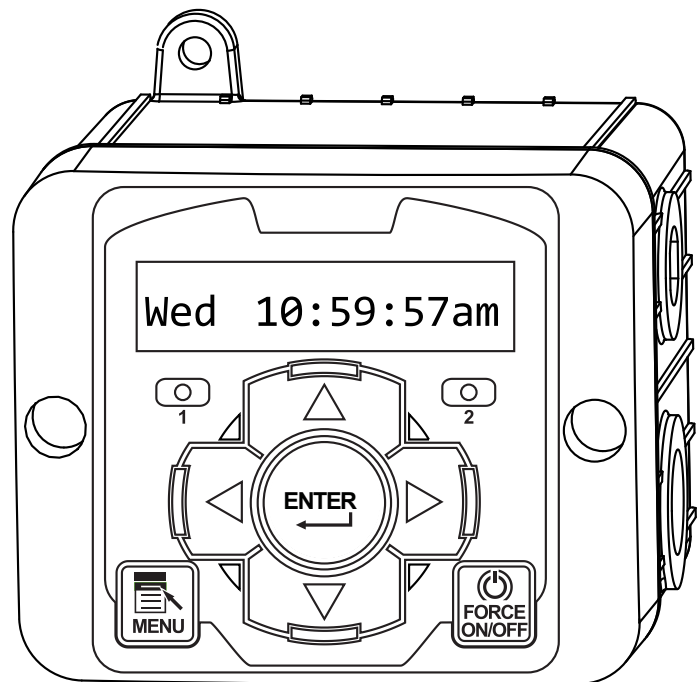

Intertek

Advantage Controls
4700 Harold Abitz Dr.
Muskogee, OK 74403
Phone: 800-743-7431
Fax: 888-686-6212
www.advantagecontrols.com
email: support@advantagecontrols.com

03/2020

Table of Contents

Contents	Page
I. Introduction.....	3
II. Description.....	3
NanoTron-P/R Features	3
III. Installation	
Electrical Wiring.....	4
Mounting Instructions	4
Logic and Relay Cards	5
Electrode Installation	6
IV. Front Panel Description	7
V. NanoTron-P/R Menu Map	8
VI. System Operation Overview.....	10
Description of Menus.....	10
VII. Maintenance	10
VIII. Troubleshooting.....	11
IX. Warranty & 30 Day Billing Memo Policy	12

I. Introduction

NanoTron microprocessor based controllers are designed to provide a wide range of control functions for recirculating water treatment systems. The controller is programmed through a front panel keypad and can be configured to provide a customized control system for your application. Your particular unit's functions can be determined by comparing the units model number to the Model Numbering table listed below.

Model Numbering

NanoTron units have several base system control functions and unit optional features. Your unit may be supplied with one or more of the features described in this manual. To determine what features apply to your unit check the model number label located on the controller enclosure. Example: NANO-P-E

Base Control Function

- P** - pH Control and 1 Feed Timer
- R** - ORP Control and 1 Feed Timer

Whole Unit Optional Features

- A** - Conduit Connections
- A3** - Conduit with CE
- E** - Flow Switch Assembly with sample port
- Y** - ETL Listing / Approvals
- W** - Larger enclosure with clear lockable cover

II. Description

NanoTron units are designed to automate pH / ORP control and the addition of various chemicals or activate other devices via a relay output.

Nano-P and Nano-R units include:

- One totalizing water meter input that can be configured for contacting head or hall effect meter inputs.
- One drum level input that can be set for one of the following: alarm display only, alarm display and force of relay 1, alarm display and force off relay 2 or alarm display and force of relay 1 & 2.
- Two mechanical relay outputs with normally open and normally closed contacts that can be configured for powered or dry contact relay operation (see page 4 diagram). Relay 1 is labeled "pH" or "ORP" and Relay 2 is labeled "Relay 2" if pigtailed are provided.
- A "force on" timer that allows for manual activation of the relays for a user defined amount of time.

pH Control (P) - The pH function monitors and controls pH on a scale of 0-14 pH units. The unit can be configured for single or dual set point control. Relay 1 is controlled by the single pH set point with the following settings: Set Point (rising for acid feed or falling for caustic feed); Differential (the amount of reading change that must occur before the relay is turned off); Limit Timer (the relay is forced off if the limit time is met).

For dual set point control to feed both an acid and a caustic the Relay 2 Set menu must be configured for Dual pH instead of a timer. This setting will add additional settings in the pH Set menu for the second set point. Relay 1 will operate off of the falling setpoint and Relay 2 off of the rising.

The High, Low Alarm settings and limit timer are the same for single or dual pH set point control.

ORP Control (R) – The ORP function monitors and controls ORP on a scale of 0 to +1000 mV using relay 1.

Relay 2 Set – The second relay can be controlled by one of the following modes: Set Point 2 for pH units, Alarms for P (not doing dual set point) or R units or one of the selectable timers below:



1. **Pulse Timer** – Accepts dry contact pulses from a water meter (supplied separately). It can accumulate 1-9999 pulses to activate the timer to run from 0-99 minutes, 59 seconds. Timer will store up to 5 additional activations during an individual run time.
2. **Recycle Timer** – Provides a user defined "off" time in HH:MM and a user defined "on" cycle in MM:SS that is repeated constantly.
3. **28-Day Timer** – 28-day feed timers, typically used for biocide feed are based on a 28-day cycle with two independent programmable feed cycles allowing for feed on selectable days and weeks.
4. **Utility** – Relay on all of the time.

III. Installation

Electrical Wiring

The controller has an internal regulated power supply that will operate in the range of approximately 100 to 240 VAC on the incoming wiring. Output relay(s) are protected with a replaceable fuse. Relay output voltage will equal the incoming line voltage.

Prewired units are supplied with a 16 AWG cable with a 3-wire grounded USA 120 volt plug for incoming power and 18 AWG 3-wire grounded receptacle cords for all control relay outputs. Conduit units are supplied with liquid tights and adaptors for easy hard wiring to supplied connector.

 CAUTION 
1. There are live circuits inside the controller even when the power switch on the front panel is in the OFF position. Never open the front panel without first disconnecting power from the outlet. Prewired controllers are supplied with an 8 foot, 18 AWG power cord with USA style plug. A #1 Phillips driver is required to open the front panel.
2. Low voltage signal wires (probes, flow switch, water meter, etc.) should never be run in conduit with high voltage (like 115VAC) wires.
3. Never attempt to land connections to the controller without first disconnecting power from the outlet.
4. Do not block access to disconnect power during mounting and installation.
5. The controller should be connected to its own isolated circuit breaker, and for best results, the ground should be a true earth ground, not shared. Any attempt to bypass the grounding will compromise the safety of users and property.
6. The electrical installation of the controller must be performed by trained personnel only and conform to all applicable National, State and Local codes.
7. Operation of this product in a manner not specified by the manufacturer may result in damage to equipment or persons.
8. Avoid mounting in locations that expose the controller to direct sunlight, vapors, vibration, liquid spills or extreme temperatures; less than 0°F (-17.8°C) or greater than 120°F (50°C). EMI(electromagnetic interference) from radio transmissions and electric motors can also cause damage or interference and should be avoided.

NOTES:

1. **Liquid tight fittings and some labeled signal leads are provided for signal (low voltage) connections, such as water meter inputs.**
2. **Hall effect meters that require +12 VDC must use an external power supply (TFS-PWR).**
3. **The 4-20mA output is produced with 12 VDC on the loop. Do not connect output to devices that are trying to power the loop.**

Mounting Instructions

Select a mounting location that provides the operator easy access to the unit and a clear view of the controls through the cover of the controller. The location should be convenient to grounded electrical connections, the sample line plumbing and is on a stable vertical surface.

Logic and Relay Cards

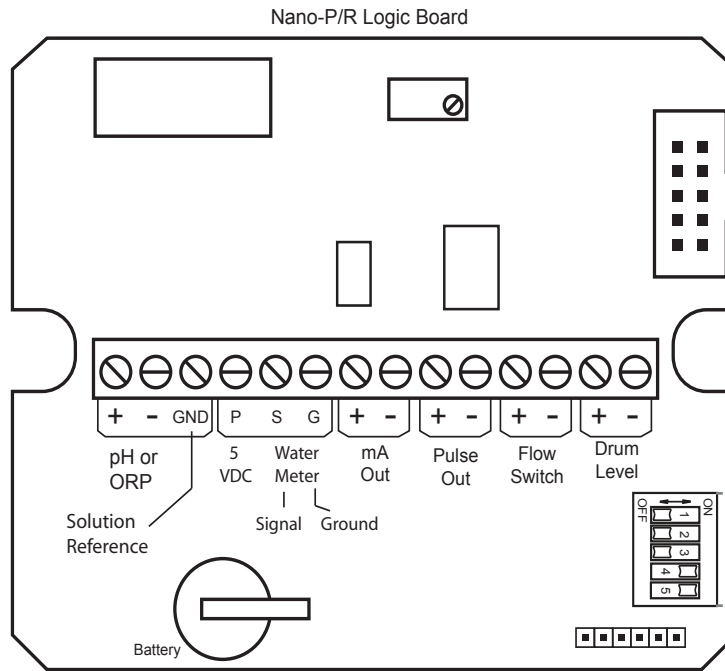
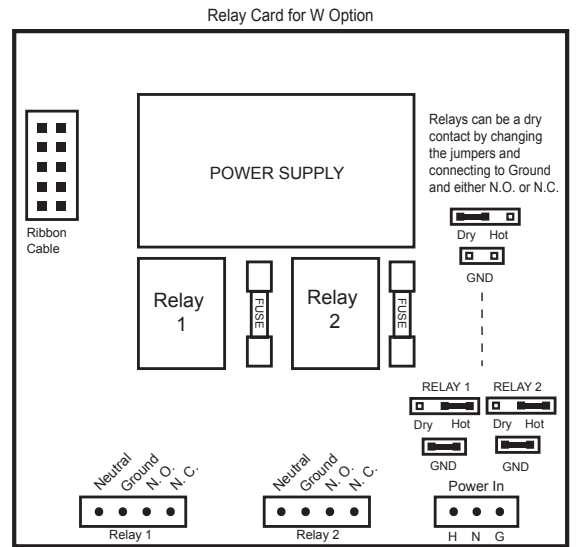
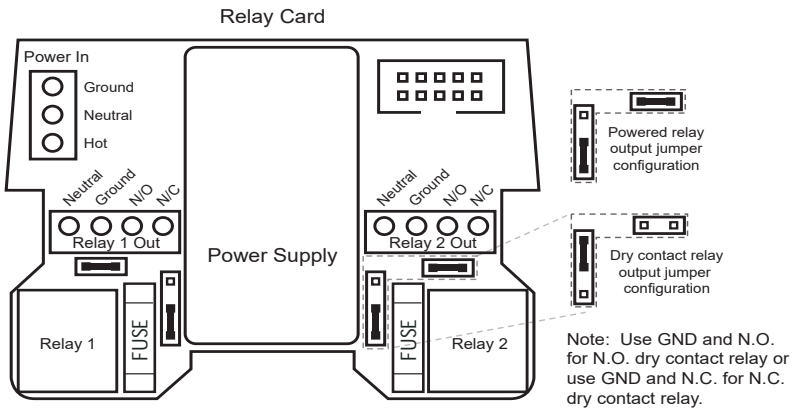

Switch #	Position	Function
1	OFF	Backlight normally off; flashes on w/ alarm
1	ON	Backlight normally on; flashes off w/ alarm
2	OFF	Normal Operation
2	ON	“Burn-in” Mode
3	OFF	Normal Operation
3	ON	Clear Memory (Resets to factory defaults)

Electrode Installation

NanoTron controllers may come configured for various circulating water systems. Listed below are instructions for typical cooling tower and boiler installations. Your specific installation requirements may differ, but should conform to these instructions as much as possible for proper operation.

A. Cooling Tower

The standard probe(s) and/or flow assembly for cooling tower installations is constructed of schedule 80 PVC and supplied with 3/4" slip fittings for installing into a sample line. To insure proper operation the sample line must have a flow rate of 3-10 gpm. Inlet pressure must be higher than outlet pressure in order for water to flow past the electrode(s) to achieve the required rate.

NOTES:

1. Install an isolation valve on either side of the flow assembly so electrode can be easily isolated for removal and cleaning.
2. A line strainer is recommended upstream from the probes to protect against fouling and damage.
3. Mount pH or ORP electrodes vertically.
4. Green solution reference wire must be connected to pH or ORP sensor.
5. Systems with a flow switch require 2-3 gpm flow rate to operate outputs.



WARNINGS:

1. Electrodes are O-ring sealed, which if damaged will cause a leak.
2. Do not allow pH sensor tips to dry out, damage will occur.
3. Do not exceed a water temperature range of 32°F to 140°F.
4. Do not exceed a maximum pressure of 125 psi.

Typical Cooling Tower Installation Diagram

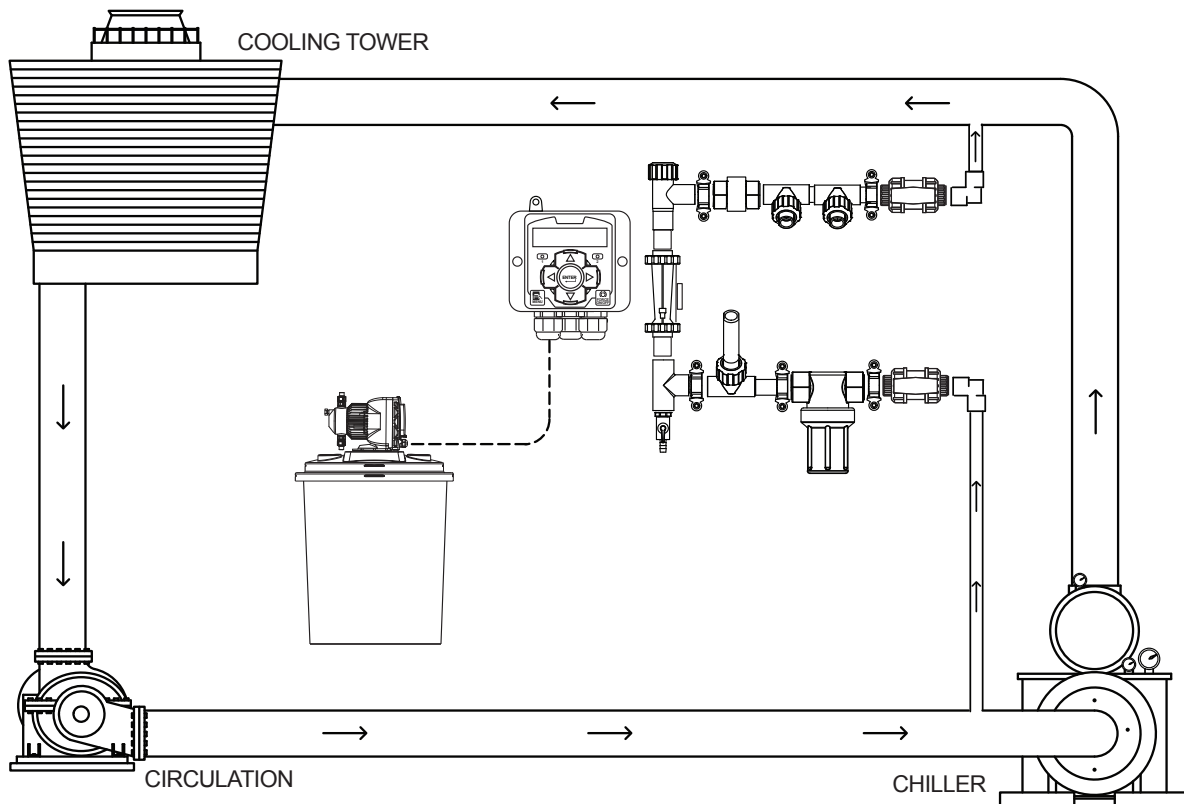

Flow Through Probe Assembly

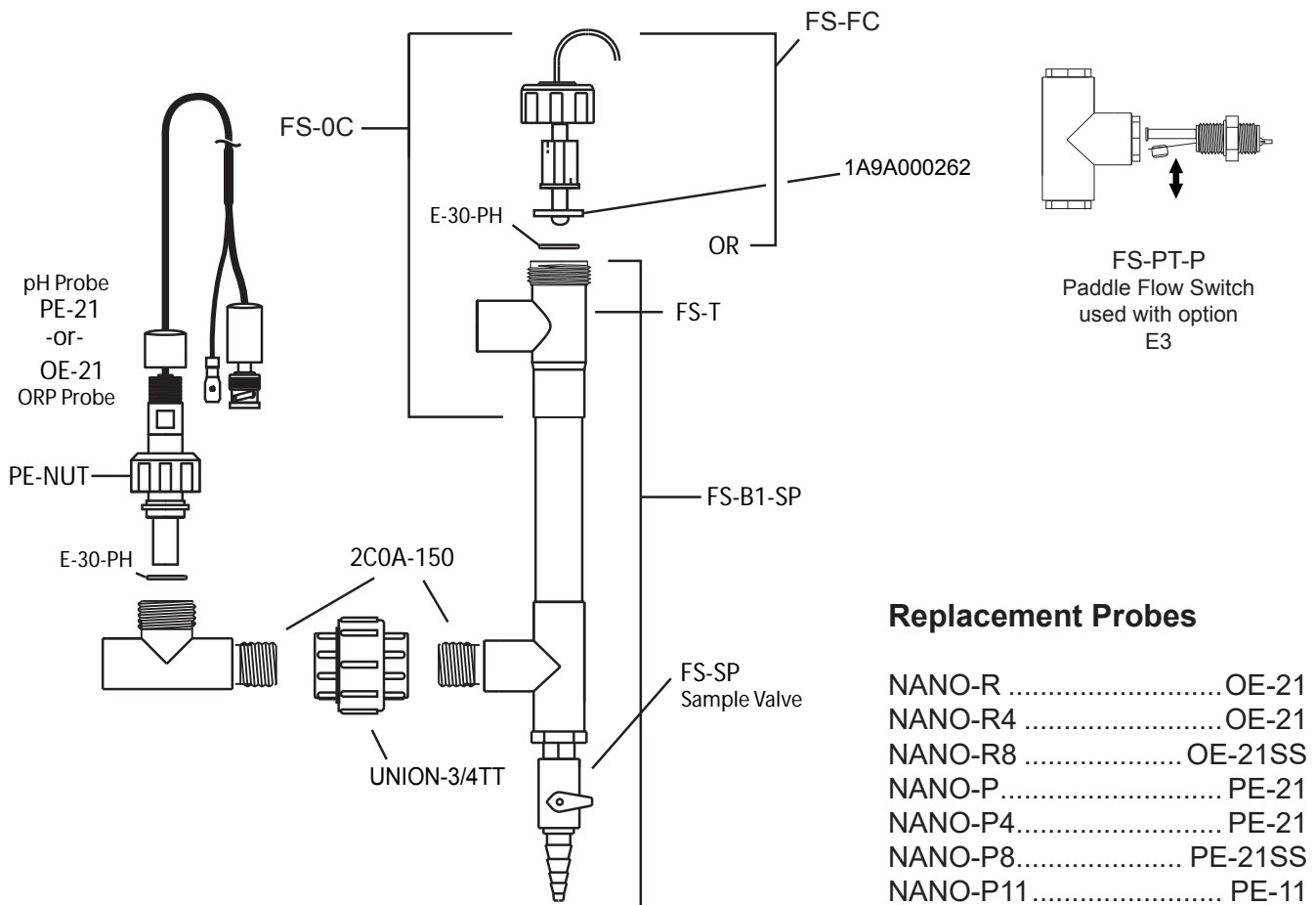

IV. Front Panel Description

The front panel features a digital display and several control buttons:

- Display:** Shows the date and time: "Wed 10:59:57am".
- Buttons:**
 - MENU:** Press MENU to access menus or go back one layer in menu structure.
 - FORCE ON/OFF:** Press FORCE to activate relays manually again for Off and a third time back to auto.
 - ENTER:** Press ENTER to go a layer deeper in menu, to initiate a setting change and to set change.
 - Navigation:** Use up or down arrows to navigate through menu selections or setting options. Use left or right arrows to move cursor while making a numerical value change.

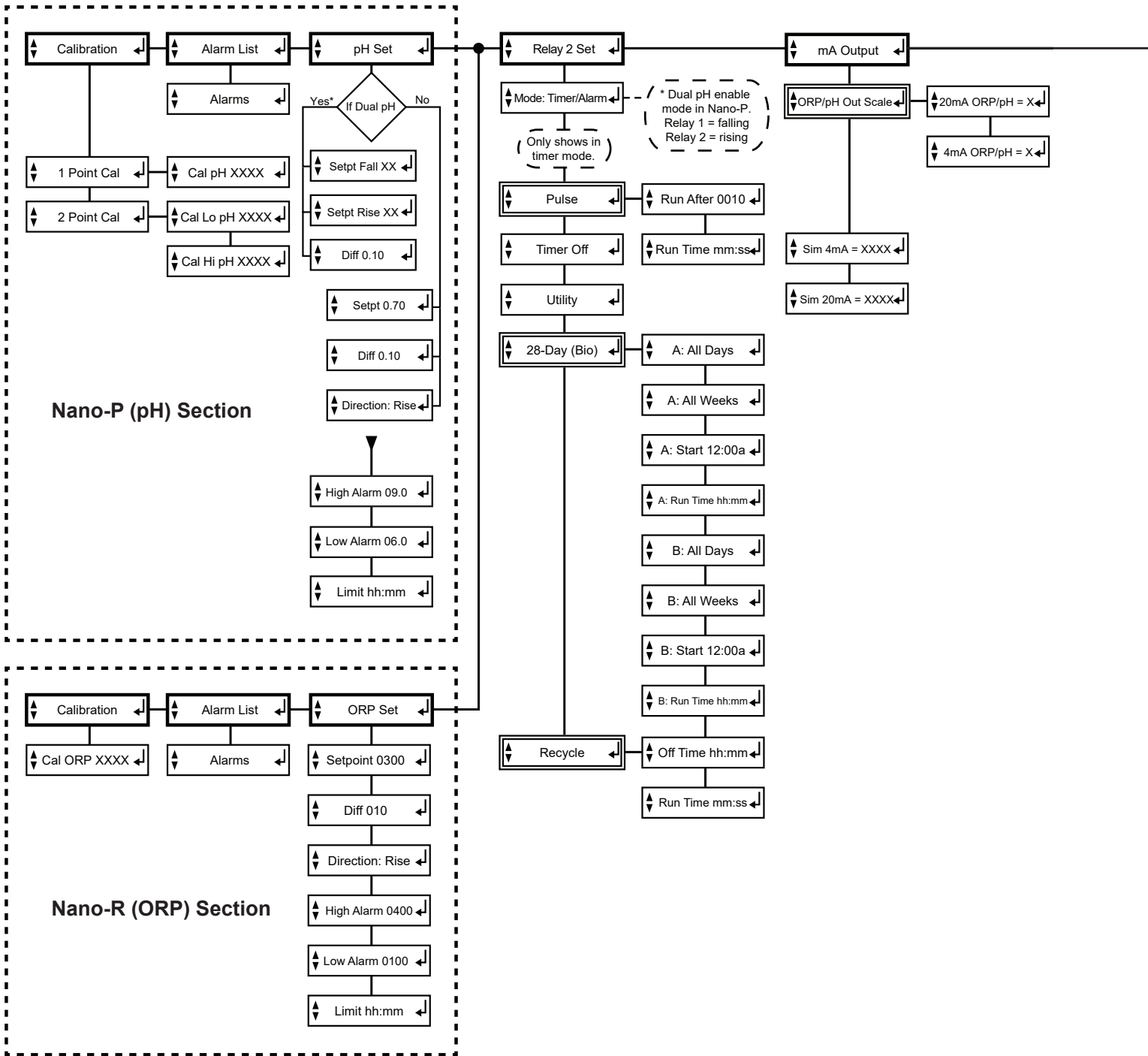

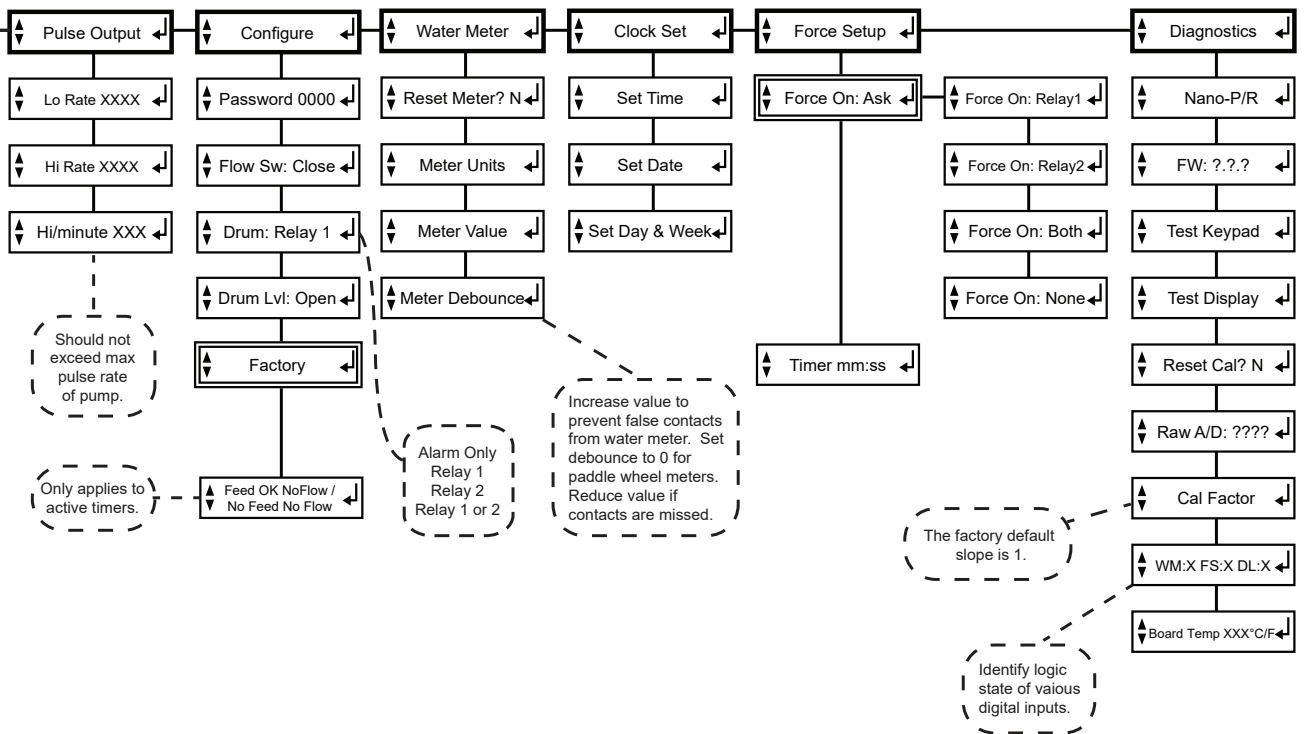

V. NanoTron-P/R Menu Map

NanoTron pH/ORP units have a main menu circle that includes:

- | | |
|---------------------|--|
| Calibration | - Calibrating the conductivity reading |
| Alarm List | - Shows active alarms |
| pH/ORP Set | - Setting the pH/ORP set point and alarms |
| Relay 2 Set | - Select the timer type and run values |
| mA Output | - Set mA output scale |
| Pulse Output | - Set pulse output scale |
| Configure | - Password, flow and drum level settings |
| Water Meter | - Reset totalizer and setting contact value |
| Clock Set | - Set time, date and week |
| Force Set | - Set the force on time for manual relay activations |
| Diagnostics | - Tests and calibration reset |

VI. System Operation Overview

Description of Menus

NanoTron controllers have three modes of operation, Run, Menu and Force. All menus are circular. Pressing the DOWN key will display the next line of information on the display.

Run - This mode is for normal operation. The control relays will only be automatically active in this mode. In the Run mode, the display will read system values. If an alarm is present, the display flashes with the alarm status.

The Run menu will display values such as day, time, date and other values depending upon the features present on the unit. The unit will automatically return to the Run mode if no keys are pressed for three minutes.

Menu - This mode is used to make adjustments to settings and readings on the controller. To access the Menu mode from the run screen, press the Menu key. Use the up or down arrow to scroll through the various menus. When you want to access a specific menu, press the Enter key. Once you have entered a sub-menu you will be able to step through that menu's options with the up or down arrow key.

Force - Relays may be forced on or off for a user defined amount of time. Press the Force key to force relays on for the time configured in the Menu's force sub-menu. Press it a second time to force them off for the same amount of time. Press a third time to go back to automatic Run mode. Unit returns to the Run mode automatically when the force time has elapsed.

VII. Maintenance

The only required maintenance for normal uninterrupted operation of your Nano-P/R controller is cleaning of the electrode. ORP and pH sensors have a 6-18 month life depending on installation and will need to be replaced regularly.

pH and ORP Electrode Cleaning Procedure

1. Remove the pH electrode from the system.
2. Spray with water and/or detergent, using a soft brush to dislodge any fouling.
3. Visually inspect the electrode for signs of damage.
4. Calibrate the electrode while it is in a known solution.

Slow response or non-reproducible measurements are signs that the electrode has become coated or clogged. The pH glass is susceptible to mounting by many substances. The speed of response, normally 95% of the reading in less than 10 seconds, is dramatically degraded when the pH glass is coated.

To restore the speed of response for a pH electrode, clean the bulb with a high quality detergent, methyl alcohol or other suitable solvent using a "Q-tip". Rinse well with distilled water and retest. If the electrode now responds, but erratically, soak the sensor in 0.1 Molar HCl for 5 minutes. Remove and rinse with water and place in 0.1 Molar NaOH for 5 minutes. Remove, rinse again and then place the sensor in pH 4. buffer for 10 minutes before use.

VIII. Troubleshooting

The Nano-P/R controller is designed for many years of trouble free operation. Should a problem occur, refer to the following chart to help identify the problem. If replacement is required, follow the procedures listed in the Warranty and Factory Service portion of this manual.

SYMPTOM	POSSIBLE CAUSE	SOLUTION
False reading.....	Bad or dirty electrode Out of calibration	Clean, as needed Calibrate unit
Will not calibrate	Dirty electrode Faulty electrode Faulty wiring to electrode	Clean electrode Replace electrode if needed Replace wiring if needed
No system power.....	Check power source Check fuse Check connections	Plug into different receptacle Replace as needed Make sure ribbon cables are secure
Pulse timer not activating	Check wiring Check external device	Repair as needed Repair/replace as needed
Outputs not energized	No flow Check fuse	Check sample line for clogged pipes or strainers Replace as needed

IX. Manufacturer's Product Warranty

Advantage Controls warrants units of its manufacture to be free of defects in material or workmanship. Liability under this policy extends for 24 months from date of installation. Liability is limited to repair or replacement of any failed equipment or part proven defective in material or workmanship upon manufacturer's examination. Removal and installation costs are not included under this warranty. Manufacturer's liability shall never exceed the selling price of equipment or part in question.

Advantage disclaims all liability for damage caused by its products by improper installation, maintenance, use or attempts to operate products beyond their intended functionality, intentionally or otherwise, or any unauthorized repair. Advantage is not responsible for damages, injuries or expense incurred through the use of its products.

The above warranty is in lieu of other warranties, either expressed or implied. No agent of ours is authorized to provide any warranty other than the above.

30 Day Billing Memo Policy

Advantage Controls maintains a unique factory exchange program to ensure uninterrupted service with minimum downtime. If your unit malfunctions, call 1-800-743-7431, and provide our technician with Model and Serial Number information. If we are unable to diagnose and solve your problem over the phone, a fully warranted replacement unit will be shipped, usually within 48 hours, on a 30 Day Billing Memo.

This service requires a purchase order and the replacement unit is billed to your regular account for payment.

The replacement unit will be billed at current list price for that model less any applicable resale discount. Upon return of your old unit, credit will be issued to your account if the unit is in warranty. If the unit is out of warranty or the damage not covered, a partial credit will be applied based upon a prorated replacement price schedule dependent on the age of the unit. Any exchange covers only the controller or pump. Electrodes, liquid end components and other external accessories are not included.

FCC Warning

This equipment generates and uses radio frequency energy and if not installed and used properly, that is, in strict accordance with the manufacturer's instruction, may cause interference to radio communications. It has been type tested and found to comply with the limits for a class A computing device pursuant to subpart J of part 15 of FCC Rules, which are designed to provide reasonable protection against such interference when operated in a commercial or industrial environment. Operation of this equipment in a residential area is likely to cause interference in which case the user, at his own expense, will be required to take whatever measures necessary to correct the interference.