

STA Oxidizer Sensors

*Free Chlorine,
ClO₂, Bromine,
Monochloramine,
Sulfite, Total
Chlorine*

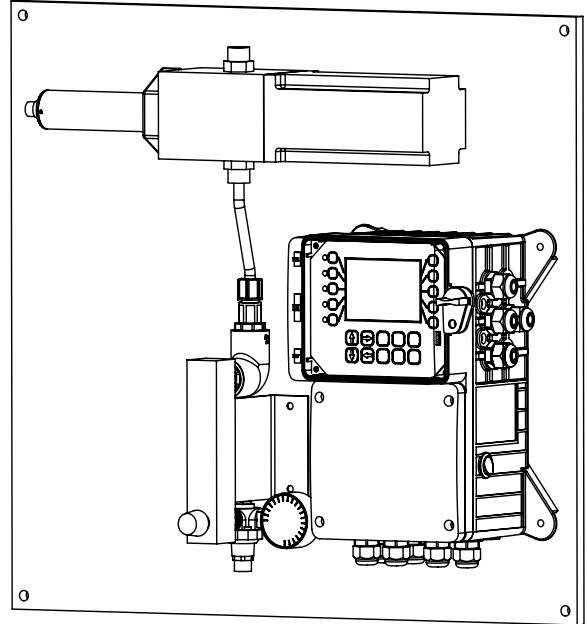

STA-FCLSS-113 depicted
Monitor not included

Key Features

- Accurate In-Line Measurement
- Compact Design
- Quick Release Tee
- Solid State Design
- Simple 4-20mA Outputs
- Easy Connection to MegaTron Controllers

Application

The STA Oxidizer membrane-less, sensors produce reliable free chlorine, chlorine dioxide, bromine, and pH readings for a wide range of applications. Temperature and pH compensation results in highly accurate oxidizer measurement.

A replaceable, front loading reference electrode assembly eliminates membranes and gel refilling while offering reduced polarization time on startup.

Applications include a wide range potable, domestic decorative water and other clean water applications. Cooling tower systems should always be used with the motorized auto cleaning option.

Advantage Controls makes integration simple and convenient with our pre-fab options.

Model Numbering

STA - - - - -

Oxidizer Type

- XXXXX = No sensor
- FCL = Free chlorine & pH SS sensor (40-104°F, 30 PSI, 0.25 GPM max) 0-5 PPM
- CLO = CLO2 & pH SS sensor (40-104°F, 30 PSI, 0.25 GPM max) 0-5 PPM
- BRO = Bromine & pH SS sensor (40-104°F, 30 PSI, 0.25 GPM max) 0-5 PPM
- NCL = Monochloramine/pH (40-104°F, 30 PSI, 0.25 GPM max) 0-5 PPM (SS only)
- SO3 = Sulfite & pH SS sensor (40-104°F, 30 PSI, 0.25 GPM max) 0-5 PPM
- TCL = Total chlorine & pH SS sensor (40-104°F, 30 PSI, 0.25 GPM max) 0-5 PPM

Sensor Body

- SS = 304 Stainless steel
- P = UPVC (FCL & CLO only)

Flow Cell

- X = No flow cell
- 1 = Self cleaning flow cell only (for tower water)
- 2 = Self cleaning flow cell with 24 VDC power supply (for tower water)
- 3 = Clean water single sensor flow cell with no cleaning motor or brush for clean water
- 4 = Clean water dual-sensor flow cell with no cleaning motor or brush for clean water
- 5 = Self cleaning with 24 VDC and auto flow control cell

Wiring

- X = No pre-wiring
- 1 = Oxidizer mA output pre-wired
- 2 = Oxidizer & pH mA output pre-wired
- 3 = No pre-wiring w/ bluetooth module
- 4 = Oxidizer mA output pre-wired w/ bluetooth module
- 5 = Oxidizer & pH mA output pre-wired w/ bluetooth module

Plumbing (1, 2, & 3 include pressure regulator, gauge and 0-1 GPM flow indicator)

- X = No plumbing
- 1 = Pre-plumbed on a separate pre-fab
- 2 = Pre-plumbed on white poly panel (not space for monitor), 22"T x 22"W
- 3 = Pre-plumbed on blue poly with space for separately-ordered XS controller: 22"T x 24"W

Specifications	
Oxidizer Range	0.00-5.00 PPM
Oxidizer Precision	± 0.01 mg/L or 1% of the value w/ pH compensation up to 9.0
pH Range	0-14
pH Precision	±0.01 pH
Sample Inlet Pressure	7.25 – 30 PSI (0.05 – 0.2MPa)
Minimum Flow Rate	200 mL/minute
Maximum Flow Rate	400 mL/minute
Sample Inlet	¼ - inch OD
Sensor Power Supply	22 – 26 VDC, Power Consumption 2W
Motorized Brush	24 VDC, <5W
Storage Temperature	-7°C – 60°C (20 – 140°F)
Outputs	Dual Isolated 4 – 20 mA Analog Outputs + Isolated RS-485 Digital Output
Sensor Dimension	Length 8.3 inch (210.8 mm), body diameter 1.4 Inch (35.6 mm)
Sensor Weight	530g (1.16lbs)
Operating Temperature	4°C – 40°C (40 – 104°F)
Wet Material	UPVC
Rating	IP67, Fully Dustproof & Waterproof
Compliance	EPA 334.0 / ISO 7393
Regulation	CE Marked / RoHS
Typical Electrode Service Life	2 years
Electrode Warranty	6 Months
Sensor Body Warranty	13 Months

Get the Advantage



4700 Harold-Abitz Dr
 Muskogee, OK 74403
 918-686-6211 Phone
 888-686-6212 Fax
www.advantagecontrols.com