

Bypass Feeder

Chemical Addition and Filtering

Installation
Maintenance
Repair
Manual

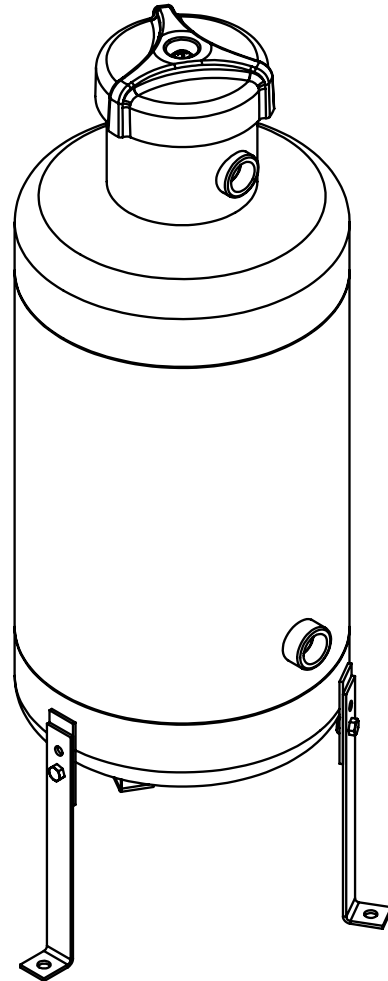

Advantage Controls
4700 Harold-Abitz Dr.
Muskogee, OK 74403
Phone: (800) 743-7431
Fax: (888) 686-6212
www.advantagecontrols.com
email: support@advantagecontrols.com

03/2026

Table of Contents

I.	Introduction	3
	Model Numbering.....	3
II.	Safety Considerations	4
III.	Installation	4
	A. Flow and Pressure Differential	4
	B. Flowrate.....	4
	C. Pressure Differential	4
	D. Temperature	4
	Installation Drawings	5
IV.	Optional Kits and Parts	5
V.	Maintenance.....	6
	A. Replacement Parts.....	6
VI.	Troubleshooting Guide	7

Manufacturer's Product Warranty

Advantage Controls warrants bypass feeders of its manufacture to be free of defects in material or workmanship. Liability under this policy extends for 12 months from date of installation. Liability is limited to repair or replacement of any failed feeder or part proven defective in material or workmanship upon manufacturer's examination. Removal and installation costs are not included under this warranty. Manufacturer's liability shall never exceed the selling price of equipment or part in question. Advantage disclaims all liability for damage caused by its products by improper installation, maintenance, use or attempts to operate products beyond their intended functionality, intentionally or otherwise, or any unauthorized repair. Advantage is not responsible for damages, injuries or expense incurred through the use of its products.

The above warranty is in lieu of other warranties, either expressed or implied. No agent of ours is authorized to provide any warranty other than the above.

I. Introduction

This manual covers all facets of operation of the Advantage Controls Bypass Feeder, including, installation, plumbing connections, optional features and start-up. Safety, maintenance, repair, warranty and factory information are also provided. Please read this manual completely before proceeding. Observe safety protocols and heed all warnings and precautions.

Model Numbering

Your Advantage Bypass Feeder may be supplied with one or more of the options described in this manual. To determine what features apply to your feeder, check the model number label located on the feeder.

Model Number (Example: **BF-05DX**)

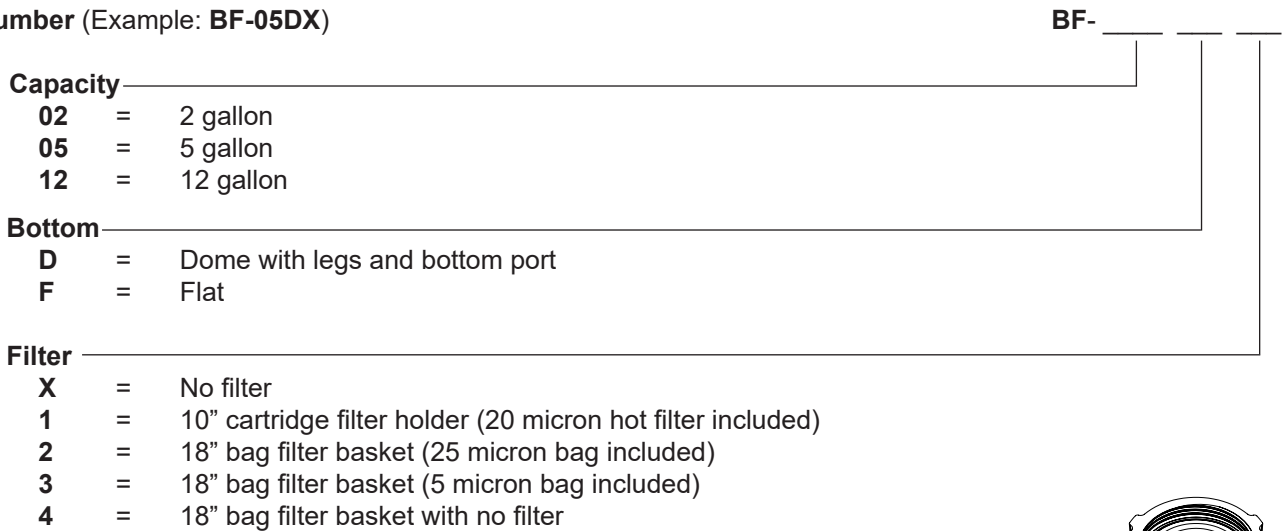

Accessory Kits

- BFK-ISOVALVES** = 3/4" brass isolation valves with unions and nipples
- BFK-DBDRAIN** = 3/4" brass drain valve and fittings for dome bottom
- BFK-FBDRAIN** = 3/4" brass drain valve and fittings for flat bottom
- BFK-GAUGEX** = 3/4" cross with 0-300 psi gauge, sample valve 180°F and fittings
- BFK-FUNASM** = 3/4" tee isolation valve and funnel

Parts

- BF-BAG0118** = 18" x 3" bag filter, 01 micron, 325°F
- BF-BAG0518** = 18" x 3" bag filter, 05 micron, 325°F
- BF-BAG2518** = 18" x 3" bag filter, 25 micron, 325°F
- BF-BAG5018** = 18" x 3" bag filter, 50 micron, 325°F
- BF-BGCAGE18-F** = Bypass feeder SS bag filter cage
- BF-CF05-10** = 10" cold water cartridge filter, 05 micron, 120°F
- BF-CF20-10** = 10" cold water filter, 20 micron, 120°F
- BF-HF05-10** = 10" hot water cartridge filter, SS core, 05 micron, 200°F
- BF-HF20-10** = 10" hot water filter, SS core, 20 micron, 200°F
- BF-CFCAGE10** = Bypass feeder SS cartridge filter holder, 10"
- BF-CAP** = Bypass feeder cap assembly
- BF-FUNNEL** = Poly funnel with 3/4" MNPT
- BF-LEGS** = Bypass feeder leg kit
- BF-PG** = 0-300 psi pressure gauge
- BF-PLATE** = Bypass feeder cap plate
- FLOW-2HT** = 3/4" flow indicator; 145 psi, 212°F max
- SFS-BV** = 1/4" brass bleed valve, 180°F max

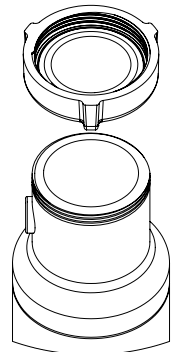

ACME Cap

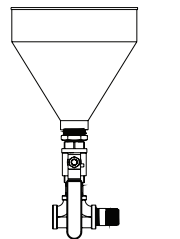

BFK-FUNASM

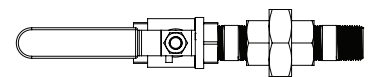

BFK-ISOVALVES

II. Safety Considerations

A. Operation

Do not install or operate the bypass feeder without reading the manual and safety protocols and warnings included. Bypass feeders are designed to operate under pressure not to exceed 200 PSI. Do not perform any maintenance or repair without first isolating the feeder from the plumbing, releasing water pressure and draining the fluid from feeder.

B. Safety and Preparation

Always wear the proper protective clothing and gear when working around chemicals and chemical metering pumps. Safety glasses, gloves, and aprons are critical in preventing accidental exposure to dangerous chemicals. Liquids under pressure can present a special hazard when a line or seal is punctured resulting in the spraying of chemical many yards away. If a chemical spill occurs, consult the Material Safety Data Sheet (MSDS) for specific instructions regarding the chemical being used.

III. Installation

Several factors must be considered when installing your by-pass feeder:

A. Flow and Pressure Differential

A bypass feeder requires a proper flow rate and pressure differential. The best way to achieve this to plumb the bypass line across the recirculation pump, or to install a throttling valve in the main line. A flow control valve is recommended to control and maintain the correct flow rate.

B. Flowrate

Advantage Control's bypass feeders are designed for a maximum flowrate of 2 GPM for 2 gallon feeders and 5 GPM for 5 and 12 gallon feeders.

C. Pressure Differential

The pressure differential should not exceed 10 PSI on non-filter filter feeder models. Feeders with either filter option should not exceed a 5 PSI differential.

D. Temperature and Pressure

All bypass feeders are rated for 200 psi (13.6 bar) @ 225°F (104.2°C) and 300 psi (20.6 bar) @ 200°F (93.3°C).

Bypass Feeder Foot Print Dimensions:

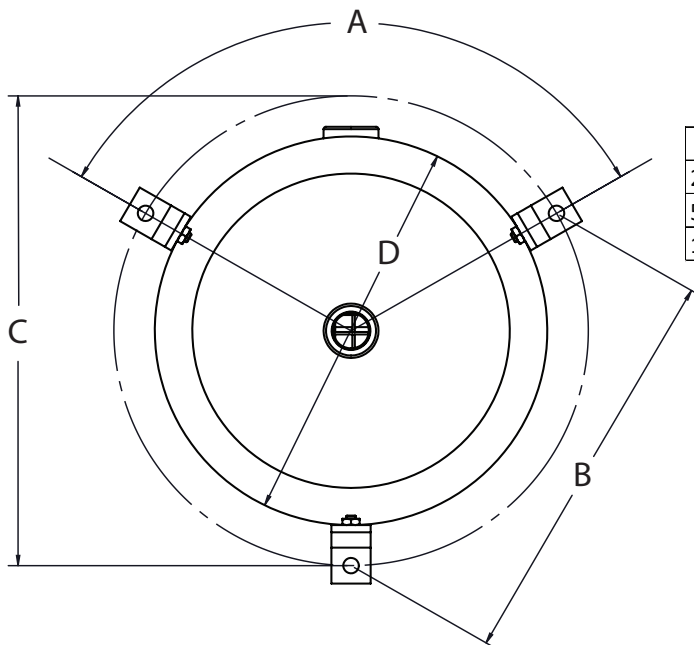

Mounting Foot Print

	A	B	C	D
2 Gal	120°	7.0" (17.78cm)	8.09" (20.55cm)	6.0" (15.24cm)
5 Gal	120°	10.47" (26.59cm)	12.09" (30.71cm)	10.0" (25.4cm)
12 Gal	120°	10.47" (26.59cm)	12.09" (30.71cm)	10.0" (25.4cm)

Typical Installations:

Bypass feeder with no filter or the pleated filter option.

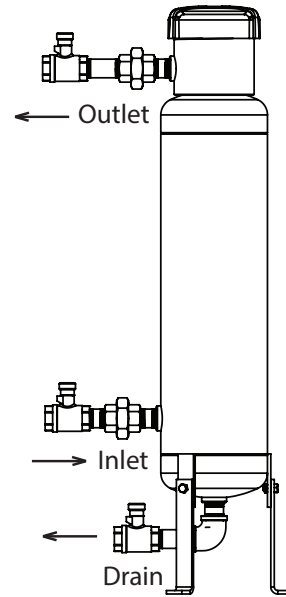
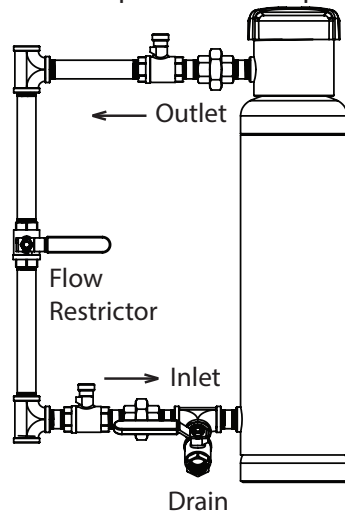

Bypass Feeder with filter bag option.

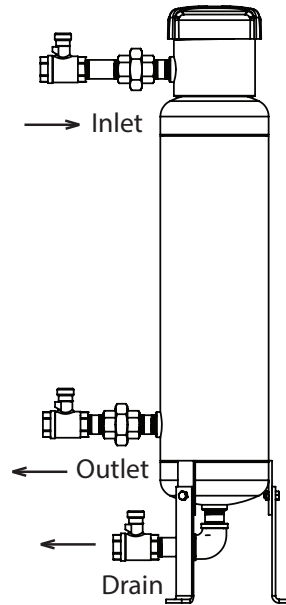
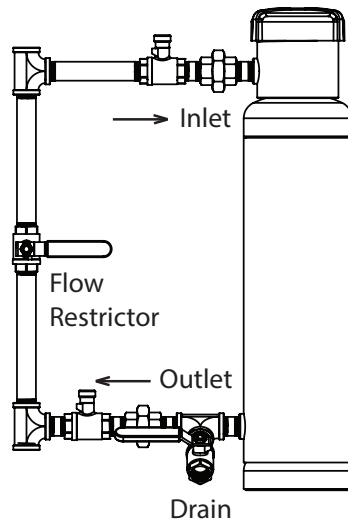

IV. Optional Kits and Parts

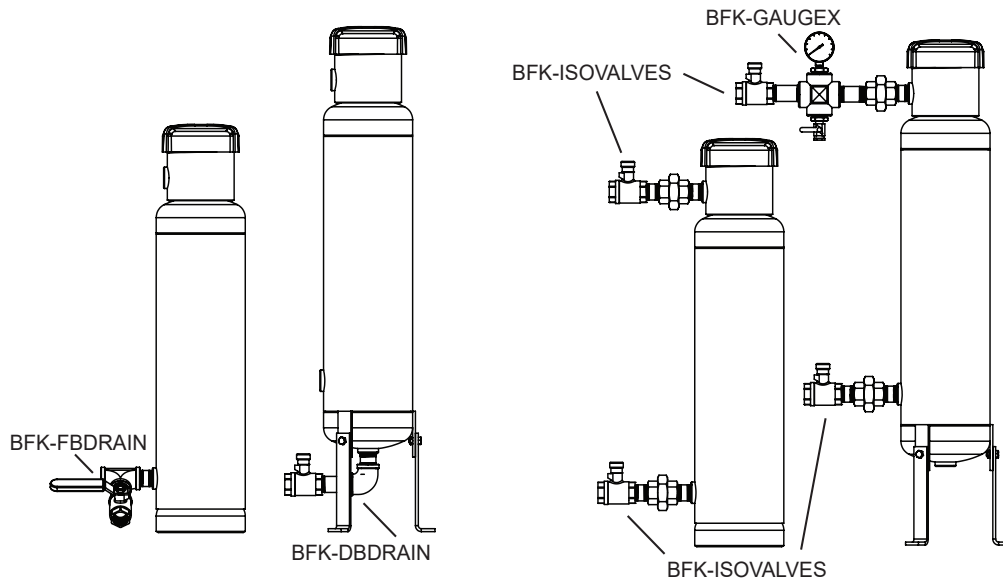

V. Maintenance

The Advantage bypass feeder is designed for long service life and minimum maintenance. If, for any reason, maintenance is necessary or desirable, the bypass feeder is easily maintained.

A. Replacement Parts

Item No.	Description	Part No.
1.....	Bypass Feeder Cap Assembly	BF-CAP
2.....	Bypass Feeder Cap Plate	BF-PLATE
3.....	Bypass Feeder Cap O-Ring	BF-ORING
4.....	Bypass Feeder Leg Kit	BF-LEGS
5.....	Bypass Feeder SS Bag Filter cage, 18"	BF-BGCAGE18
6.....	Bypass Feeder SS Cartridge Filter Cage, 10"	BF-CFCAGE10
7.....	0-300 PSI Pressure Gauge	BF-PG
8.....	$\frac{3}{4}$ " Brass Ball Valve Kit	BFK-ISOVALVES
9.....	$\frac{1}{4}$ " Brass Bleed Valve, 180°F max	SFS-BV
10.....	$\frac{3}{4}$ " Flow Indicator; 145 PSI, 212°F max (0-10 GPM)	FLOW-2HT
11	$\frac{3}{4}$ " Brass Ball Valve	GV-3/4
12.....	Dome Bottom Drain Valve Kit	BFK-DBDRAIN
12A.....	Flat Bottom Drain Valve Kit	BFK-FBDRAIN
13	Pressure gauge and air bleed valve with cross	BFK-GAUGEX
14.....	$\frac{3}{4}$ " tee, isolation valve and funnel kit	BFK-FUNASM

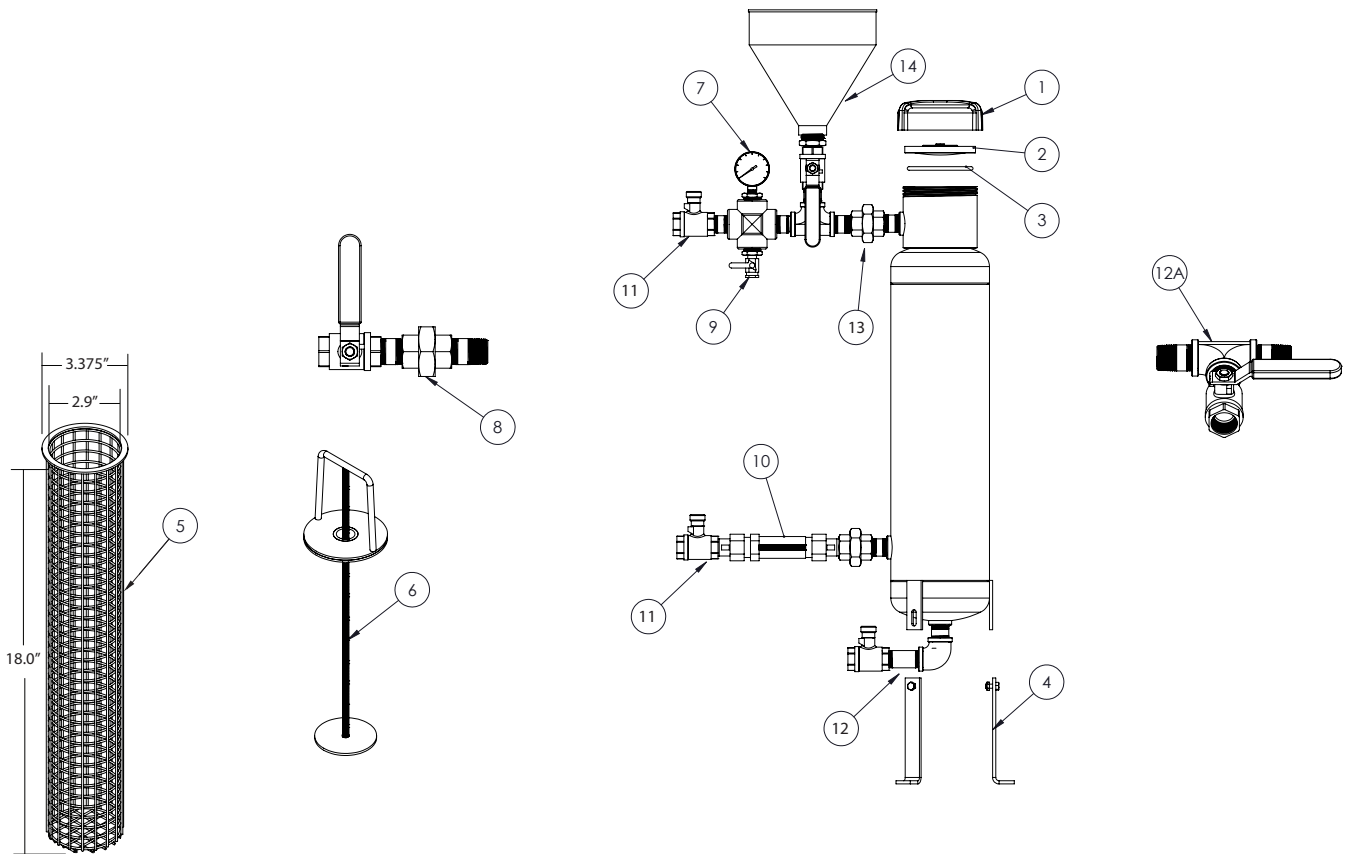

VI. Troubleshooting Guide

SYMPTOM	CAUSE	ACTION
Leaking at cap	Improper seating of o-ring	Remove cap, clean surface and reseal cap and closure. If problem persists, replace o-ring.
Leaking at fittings	Improper seal or threading of fittings	Remove fitting and sealant and inspect threads for damage. If there is no damage, apply sealant (thread tape or pipe dope) and reseal fitting. Replace fitting if the problem persists.
Filter damage	High particle content or excess flow rate	Check flow rate and valves. Inspect chamber for solids. Adjust valves and replace filter. Large particle content is often a typical problem during start up.
Interior corrosion	Trapped air or chemical content	Evidence of corrosion near the inside of vessel fill port is an indication of excessive trapped air. To remove trapped air, close isolation valves and fill feeder to the brim and reinstall closure. This should be done by trained personnel. Check with chemical supplier for compatibility if corrosion is covering body interior. Do not use feeder if there is excessive corrosion.
Leaking feeder body	Unidentified pinhole during manufacture or excessive use	Occasionally, trapped gas during manufacturing may cause pin leaks to occur upon installation. Vessels that begin to leak after some time of service may be exhibiting normal wear. Typically there is no way to repair a vessel that exhibits wear, and replacement may be necessary. Consult the factory for recommendation.

Get the Advantage in Water Treatment Equipment

Advantage Controls can give you the Advantage in products, knowledge and support on all of your water treatment equipment needs.

- Cooling Tower Controllers
- Boiler Blow Down Controllers
- Blow Down Valve Packages
- Solenoid Valves
- Water Meters
- Chemical Metering Pumps
- Corrosion Coupon Racks
- Chemical Solution Tanks
- Solid Feed Systems
- Feed Timers
- Filter Equipment
- Glycol Feed Systems
- Pre-Fabricated Systems

