

# MegaTron WEBX



## Touch Screen Web Monitor

### Product Manual



#### Important Safety Instructions

Read all warnings and instructions in this manual.  
Save all instructions.



Advantage Controls  
4700 Harold-Abitz Dr.  
Muskogee, OK 74403  
Phone: 918-686-6211  
Fax: 888-686-6212  
www.advantagecontrols.com  
support@advantagecontrols.com

# MegaTron WEBX Web Monitor Instruction & Maintenance Manual Table of Contents

Contents	Page
I. Introduction.....	3
Model Numbering.....	3
Description of Unit.....	3
II. Intended Use.....	4
Mechanical Specifications.....	4
Icon Definitions.....	4
III. Installation.....	4
A. Electrical Wiring Information.....	4
B. Mounting Location Information.....	5
Back Pane and System Card Connections.....	6
Wiring Diagrams.....	7
IV. Front Panel.....	9
V. System Operation Overview.....	10
Start-Up.....	10
VI. Menu Navigation.....	11
VII. Maintenance.....	22
VIII. Warranty & 30 Day Billing Memo Policy.....	22

# I. Introduction

The MegaTron WEBX microprocessor-based controllers are programmable through a front panel touch screen and can be configured to control a wide range of digital and analog inputs. Your particular unit's functions can be determined by comparing the units model number to the Model Numbering table listed below.

## Model Numbering

MegaTron WEBX units have several base system control functions and unit optional features. Your unit may be supplied with one or more of the features described in this manual. To determine what features apply to your unit check the model number label located on the controller enclosure.

**Build a Model ..... WEBX - X A X X 1 A X**

### Step 1 system card functions

<b>Power Options</b>		95-230 VAC
X	95-230 VAC incoming no 24 VDC	
1	95-230 VAC incoming plus 24 VDC	
<b>Relay Options</b>		(2.5 amp each)
A	(5) dry contact relays	
B	(5) powered relays / conduit	
C	(5) powered relays with liquid tights	
D	(5) powered relays with USA pigtails	
<b>mA In/Out Signals</b>		8 signals max
X	None	
1	(4) mA inputs	
2	(4) mA output control	
3	(4) mA inputs and outputs	
4	(8) mA inputs	
5	(12) mA inputs	
6	(16) mA inputs	
7	(8) mA inputs and outputs	
<b>Flow Meter (Pulse) Inputs</b>		
X	None	
A	(5) totalizing flow meter inputs	
<b>Digital Inputs</b>		
1	(5) digital inputs with alarms	
2	(12) digital inputs with alarms (mA options 1-4 only)	

<b>Communications Card Options</b>	
A	WebAdvantage only
B	Modbus via ethernet and WebAdv
C	BACnet via ethernet and WebAdv
<b>Cellular Service Options</b>	
V=Verizon™, A=AT&T™	
X	None
A	Internal router w/ 12 months (V)
B	External router w/ 12 months (V)
C	Internal router with no data
D	Internal router w/ 12 delayed (V)
E	Internal router w/ 12 months (A)
F	External router w/ 12 months (A)
<b>Additional Enclosure Options</b>	
1	Clear cover
2	Black cover

Notice: Your unit may not have all features and functions described in this manual. This list represents our most popular options, additional option codes are available. Consult representative for more details.

## Description of Unit

MegaTron WEBX controllers can control single or multiple recirculating water systems, including cooling tower and boiler applications, and may have various features depending on the model number.

# II. Intended Use





 The MegaTron WEBX is a microprocessor-based monitoring instrument used to track parameters and other process variables in a wide range of applications.

 Operating the instrument in any way other than as described in these instructions may compromise the safety and function of the measuring system and is therefore impermissible. Electrical connection work and maintenance work may only be carried out by qualified personnel. The manufacturer is not liable for damage caused by improper or non-designated use.

## Mechanical Specifications

<b>Electrical Input</b>	100-230 VAC, 50/60 Hz, 2A rated
<b>Relay Outputs</b>	Individually fused and 2.5 amps. Dry contact limited to 2.5 mA at 28 VDC.
<b>Display</b>	7" Diagonal LCD Touch Screen
<b>Digital Inputs</b>	Inputs have 10K $\Omega$ pullup to 3.3 VDC from open collector open drain output
<b>Flow Totalizing Inputs</b>	10K $\Omega$ pullup to 5 VDC max rate 2.5 KHz from open collector open drain output
<b>mA Inputs</b>	Optical isolation, 250 $\Omega$ / 5 VDC @ 20 mA. Loop voltage to not exceed 30 VDC.
<b>mA Outputs</b>	Non-isolated. 12 VDC max load = 400 $\Omega$ . Isolated ext 24 VDC max load = 800 $\Omega$ .
<b>Approvals</b>	CE, UL61010-1& CSA C22.2 No. 61010-1-12 3rd edition + A1:2022 (R2022)
<b>Enclosure</b>	NEMA 4X style polycarbonate
<b>Ambient Temp</b>	0° to 125°F (-17° to 52°C)
<b>Shipping Weight</b>	Approximately 10 lbs. (4.536 kg)
<b>Dimensions</b>	11" (27.94cm) W x 11.75" (29.84 cm) H

## Icon Definitions

Symbol	Publication	Description
	IEC 417, No. 5019	Protective Conductor Terminal
	IEC 417, No. 5007	On (Supply)
	IEC 417, No. 5008	Off (Supply)
	ISO 3864, No. B.3.6	Caution, risk of electric shock
	ISO 3864, No. B.3.1	Caution

## III. Installation

### A. Electrical Wiring Information

The controller has an internal regulated power supply that will operate in the range of approximately 100 to 230 VAC on the incoming wiring. Output relay(s) are protected with a replaceable fuse. Relay output voltage will equal the incoming line voltage.

Your controller will arrive from the factory prewired or ready for hardwiring. Depending on your configuration of controller options, you may be required to hardwire some or all of the input/output devices.

**Note:** When wiring the optional flow meter contactor input, the 4-20 mA outputs or a remote flow switch, it is advisable to use stranded, twisted, shielded pair wire between 22-26 AWG. Shield should be terminated at the controller at the most convenient shield terminal.

Prewired units are supplied with a 16 AWG cable with a 3-wire grounded USA 100 volt plug for incoming power and 18 AWG 3-wire grounded receptacle cords for all control relay outputs. Conduit units are supplied with liquid tights and adaptors for easy hard wiring to supplied connector.



## CAUTION



1.	There are live circuits inside the controller even when the power switch on the front panel is in the OFF position! The front panel must never be opened before power to the controller is REMOVED! If your controller is prewired, it is supplied with an 8 foot, 18 AWG power cord with USA style plug. A tool (#1 Phillips driver) is required to open the front panel.
2.	Low voltage signal wires (probes, flow switches, water meter, etc.) should never be run in conduit with high voltage (like 100VAC) wires.
3.	Never attempt to land connections to the controller without first disconnecting power from the outlet.
4.	Do not block access to disconnect power during mounting and installation.
5.	The electrical installation of the controller must be done by trained personnel only and conform to all applicable National, State and Local codes!
6.	Proper grounding of this product is required. The controller should be connected to its own isolated circuit breaker, and for the best results, the ground should be a true earth ground, not shared. Any attempt to bypass the grounding will compromise the safety of persons and property.
7.	Operating this product in a manner not specified by the manufacturer may impair the protection provided by the equipment.
8.	Only power device with cover installed. Never operate device with cover removed.

### Additional Notes:

1. Liquid tight fittings and some labeled signal leads are provided for signal (low voltage) connections, such as water meter inputs.
2. Hall effect meters that require +12 VDC must use an external power supply (TFS-PWR).
3. Optional 4-20mA output is produced with 12 VDC on the loop. Do not connect output to devices that are trying to power the loop.

### B. Mounting Location Information

1. Select a mounting location that provides the operator easy access to the unit and a clear view of the controls through the cover of the controller. The location should be convenient to grounded electrical connections, the needed sample line plumbing and is on a stable vertical surface.
2. Do not block access to disconnect power during mounting and installation.
3. Avoid mounting in locations that expose the controller to direct sunlight, vapors, vibration, liquid spills or extreme temperatures; less than 0°F (-17.8°C) or greater than 120°F (50°C). EMI (electromagnetic interference) from radio transmissions and electric motors can also cause damage or interference and should be avoided.
4. Minimum screw / bolt size is #8 or larger.

# Back Pane and System Card Connections

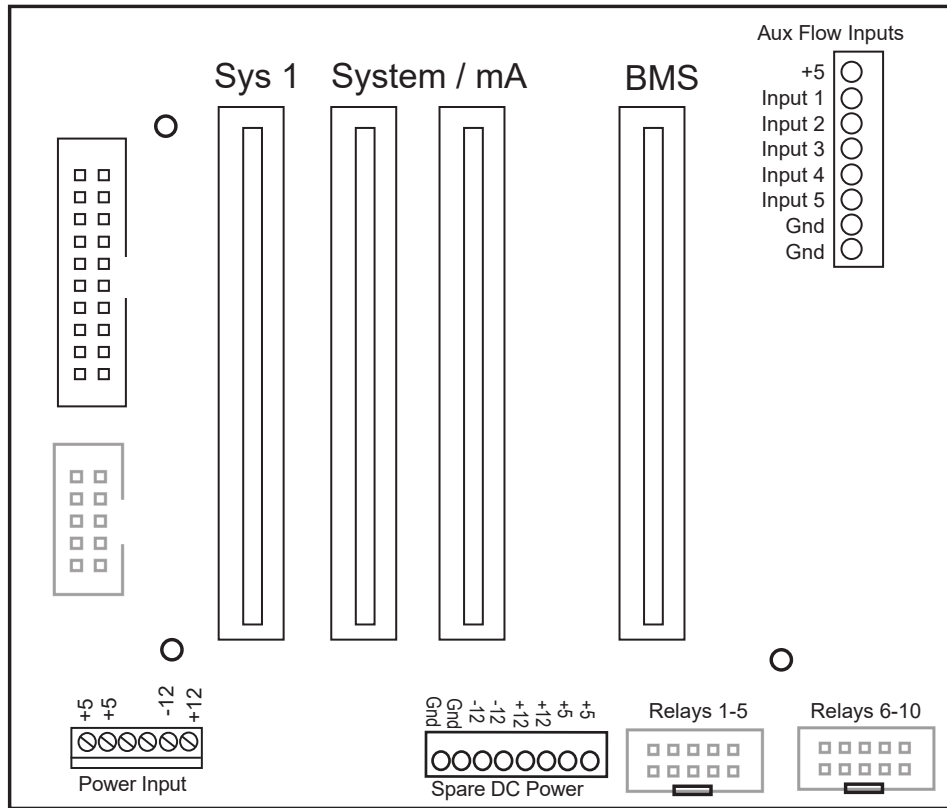

# Wiring Diagrams

## Optional Powered Relay Card Wiring

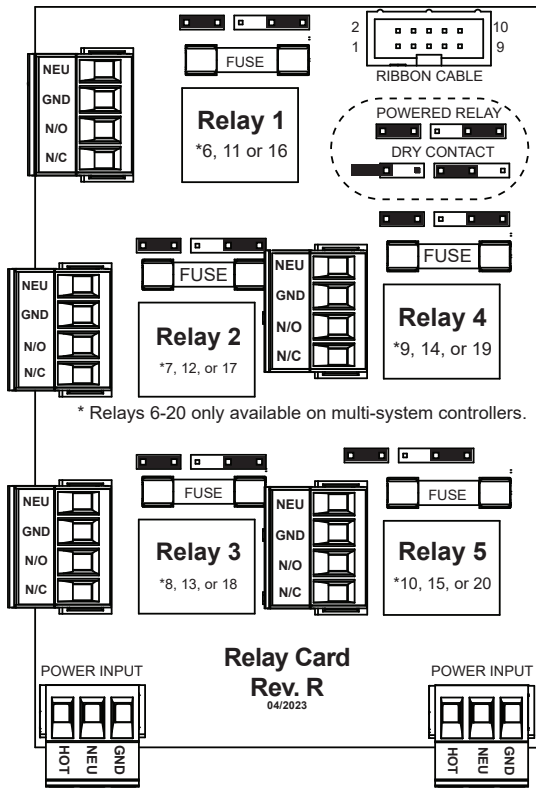

## System Card Connections

Typically High Level

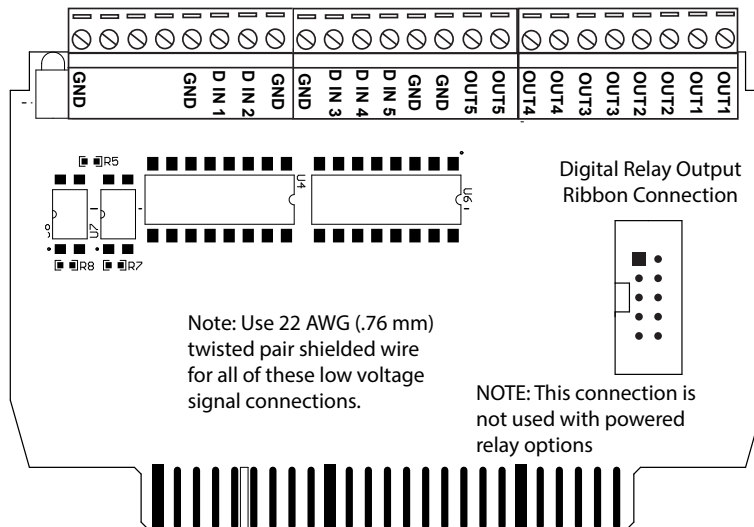

## 4-20mA Output Card Wiring

### A. Isolated Configuration

For isolated 4-20mA outputs an external power source for the loop must be supplied. JP4 and JP5 on the board must be jumpered for isolated, with an external power source supplied to the external VDC input. The external power source must not exceed 24 volts DC.

### B. Non-isolated Configuration

For non-isolated 4-20mA outputs the controller will supply the power for the loop. JP4 and JP5 must be jumpered for non-isolated, and no connections are made to the external VDC points.

**NOTE:** The power for the mA output loop is always provided by the controller with either isolated or non-isolated configuration.

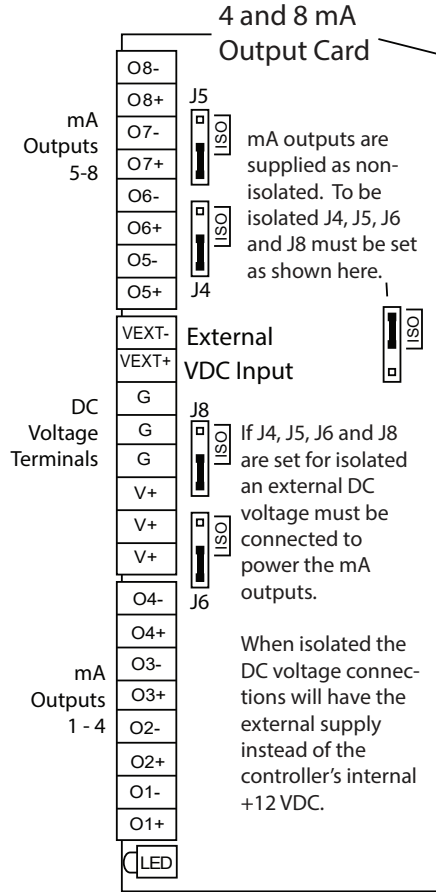

## 4-20mA Input Card Wiring

The 4-20mA input card requires that the external device sending the 4-20mA input signal(s) supply the power for the loop. The external power source must not exceed 24 volts DC.

**NOTE:** Older green versions of the 4 input cards supply +12 VDC and ground on the voltage terminals, and newer blue versions supply +12 and -12 VDC instead of ground on the "G" positions, if not configured for isolated voltage.

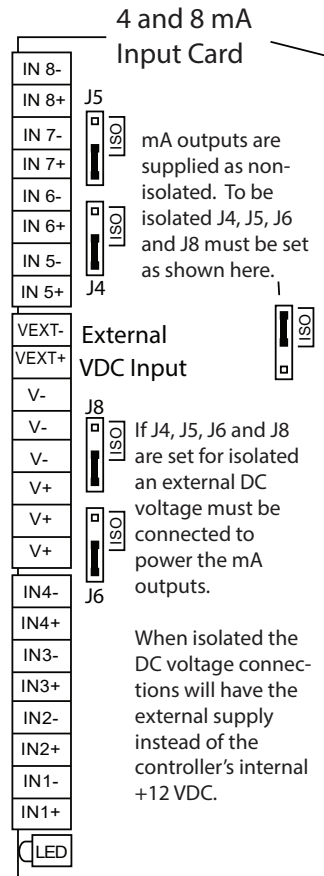

## IV. Front Panel Description

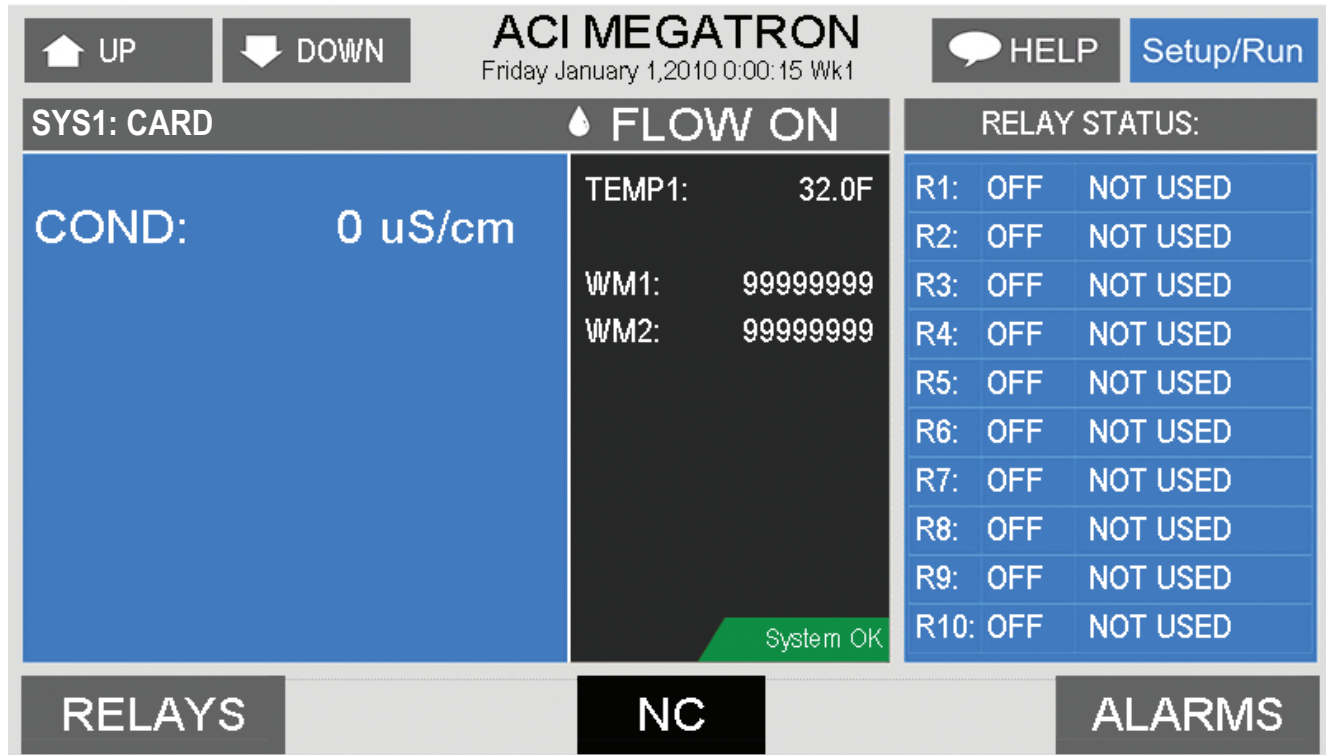

- SET UP/RUN - System initializes into RUN mode. Press this key to put the controller in SET UP Mode and see HOME menu page.
- HOME - Used to go back to the HOME menu page.
- HELP - Used to access help screens.
- BACK - Used to go back to last menu screen viewed or clear values keyed in that are not wanted.

The default is the RELAY status menu, but this can be changed by navigating to the desired screen and pressing the HELP button. Follow the on-screen instructions to set the new hot key location.

## V. System Operation Overview

### Operation

MegaTronXT controllers have two modes of operation, RUN and SET-UP.

**RUN** - This mode is for normal operation. In the RUN mode the display will show each system's parameters. If an alarm is present, the ALARM box will flash how many alarms are activated. No settings may be entered or changed in the RUN mode. Readings are updated every 6 seconds on the screen while in the RUN mode.

**SET-UP** - This mode is used to make adjustments to settings and readings on the controller. To access the SET UP mode from the RUN screen, press the SETUP/RUN key.

### Typical Start Up Instruction

Complete all installation steps before beginning this procedure. Ensure that all controlled devices (pumps, solenoid valves, etc.) are operational and connected to the controller. Open the isolation valves to allow water to pass through the sample stream assembly. Before beginning the startup procedure, familiarize yourself with the programming and operation of the system by reviewing the menus available. Use the keys of the controller to skim through all your options.

## VI. Menu Navigation

To access the menus, press the Set Up / Run key on the front panel. This takes you to the Home menu. MegaTronXT controller's menus are easily navigated by pressing the associated number key next to a menu box on the screen. Once you have stepped through the sub menus to reach a point at which a value or selection is made, a Pop-up window will appear prompting you to enter a desired value or selection.

**NOTE:** When entering new numeric values, enter all available digits (characters).

### 1. Home Menu

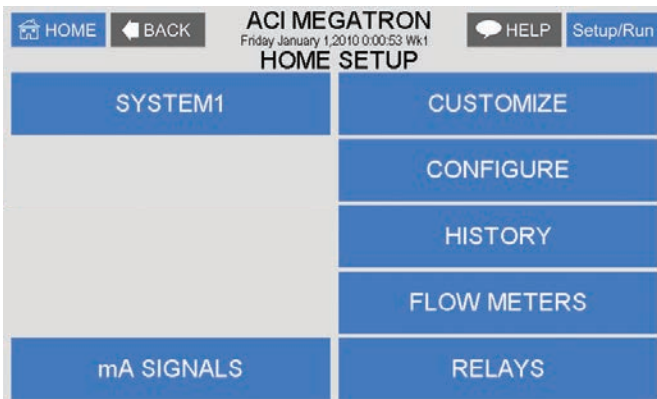

From the **HOME** menu select the desired menu. The menu name explains what parameters can be programmed in the menu.

- SYSTEM1** - Setting control set points
- CUSTOMIZE** - Giving the controller, each system, mA input, and all relays a user-defined name.
- mA SIGNALS** - Menus for setting mA inputs and outputs calibration and control settings.
- CONFIGURE** - Menus for configuring passwords, relay activations, setting history interval, flow switch, contrast, temperature scale.
- HISTORY** - Allows for view history on board in a graph form.
- FLOW METERS** - Menu for configuring flow meter totalizing.
- RELAYS** - Menu for resetting accumulated "ON" times and manual relay activation.

### 2. Aux Inputs

Auxiliary inputs are the digital inputs for optional Flow Switch and other digital inputs, such as low drum level alarms. From these menus, alarms, notification, action, and latching settings can be made.

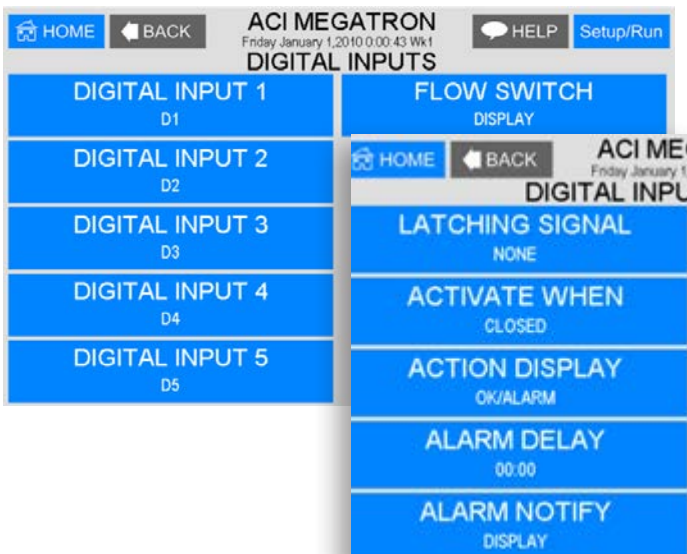

- LATCHING SIGNAL** - Allows a digital input to stay Active until a second latched input becomes active.
- ACTIVE WHEN** - Set if input is active seeing closed or open.
- ACTION DISPLAY** - Set if the input is being set as alarm or just On/Off.
- ALARM DELAY** - How long input must be in open/closed before registering.
- ALARM NOTIFY** - Set the alarm notification.

## 2.1. Water Meters / Totalizers

Each system with a timer on it will have 2 water meter inputs. Each of these can have the incoming contact defined, allowing the controller to keep track of water usage. If desired, the controller can calculate evaporation loss by subtracting the difference between a system's two water meter inputs.

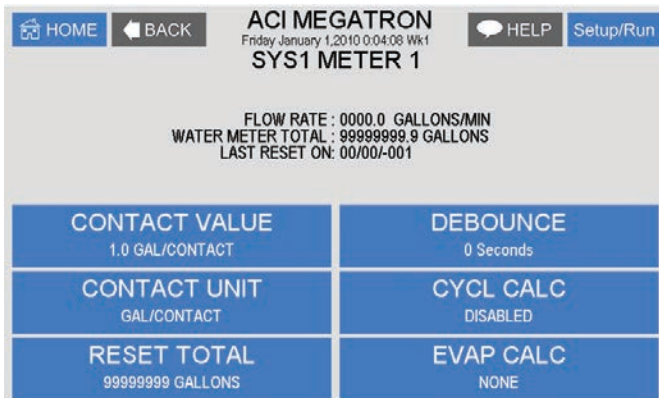

**CONTACT VALUE** - Defines the numerical value for a contact; i.e. 10.

**CONTACT UNIT** - Defines the units of measurement for a contact; i.e. Gallons / Contact. If there is a mA input set for a gpm or lpm reading, that mA input can be selected in the Contact Units as the source for the meter input to total flow rate.

**RESET TOTAL** - Resets the totalizer count.

**EVAP CALC** - Defines which way to subtract the two water meter inputs for an evaporation value.

**DEBOUNCE** - An additional amount of time the input will wait before accepting another water meter contact to reduce false contacts from a chattering read switch.

### 2.1.a. Option W Totalizers

MegaTronXT controllers with "W" option may have 1 to 4 auxiliary flowmeter inputs. These additional inputs are for tracking various flow meter devices (additional water meters or flowmeters in a metering pump's discharge tubing). They can also be linked to a system's water meter input for additional tracking and alarm capabilities, including bleed flow/no flow, exceeding too much flow in a 12- or 24-hour period. Units with Auxiliary Flow meter inputs have a Home menu selection for Totalizers. The Totalizer menu has selections for each of the System Water Meters, plus one named Aux Meters.

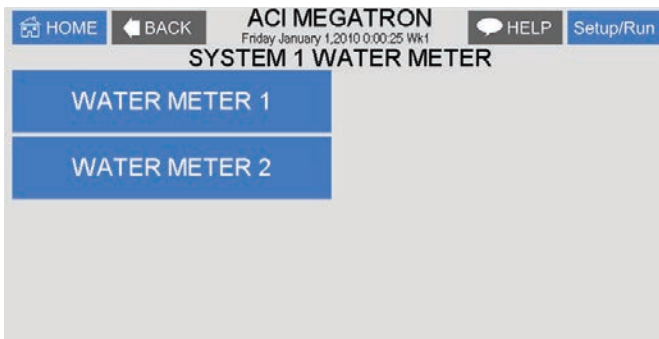

Select the system water meter to set up or go to Aux Meters to set-up the auxiliary flow meters.

## 3. mA Signals

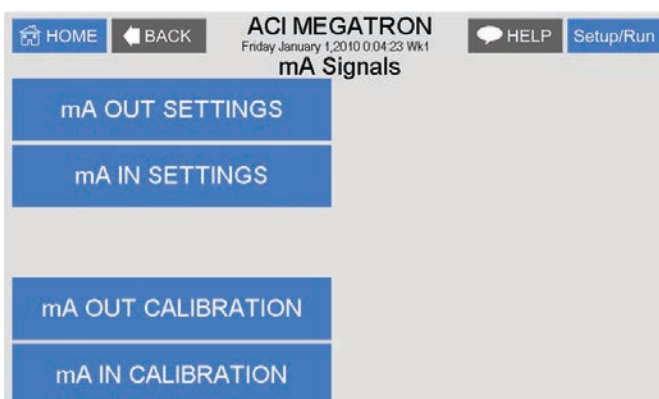

**mA OUT SETTINGS** - Selecting source and range of outputs.

**mA IN SETTINGS** - Setting control and alarms for inputs

**mA OUT CALIBRATION** - Calibrating outputs.

**mA IN CALIBRATION** - Calibrating inputs and displayed range.

### 3.1. 4-20mA Out Settings

Units with a 4-20mA output option will have a menu for setting up the 4-20mA output. The 4mA and 20mA values can be defined by giving the output proportioning capability. i.e. 4mA = a pH of 6.0 and 20mA = a pH of 8.0.

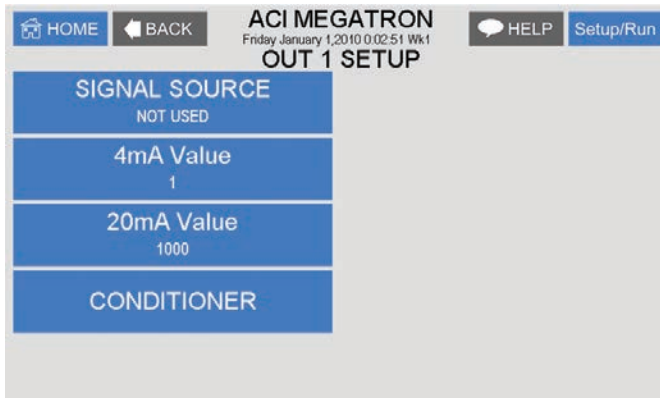

**SIGNAL SOURCE** - Select which probe reading the mA will use as its reading source.

**4 mA VALUE** - What the 4mA signal equals

**20mA VALUE** - What the 20mA signal equals on the assigned signal sources scale.

**CONDITIONER** - Select a second reading that can change or condition the original mA output.

### 3.2 4-20mA Input Settings

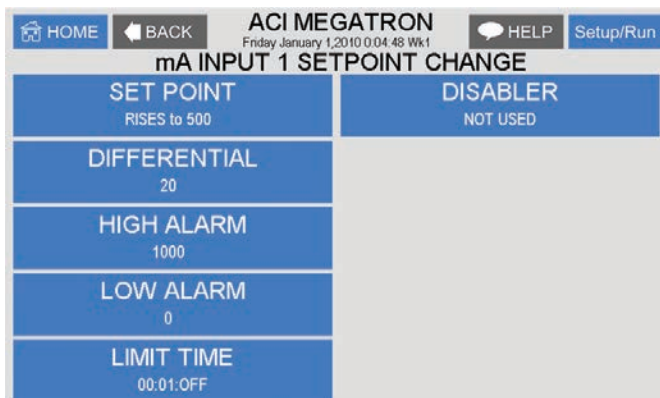

**SET POINT** - What reading turns the relay on

**DIFFERENTIAL** - Amount reading changes by before the relay is turned off.

**HIGH ALARM** - What reading generates a High alarm notification.

**LOW ALARM** - What reading generates a Low alarm notification.

**DISABLER** - Selected input will disable HIGH/LOW alarm notifications and a control relay being activated by the input's setpoint.

### 3.3 4-20mA Output Calibration

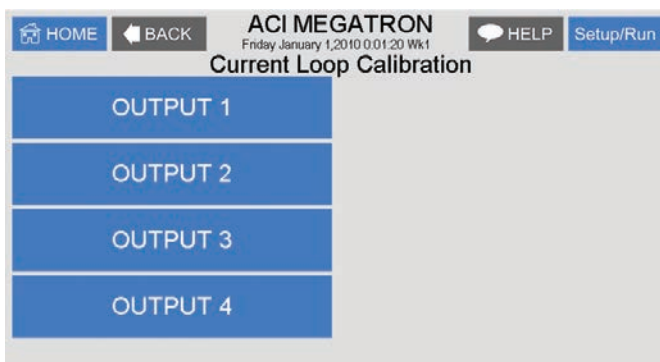

4-20mA outputs can be calibrated to ensure that the output generated by the controller and received by the external device match. With a voltmeter connected across the out and return wires (see page 7) of the 4-20mA output channel, to be calibrated, go into the output's Low or High calibration.

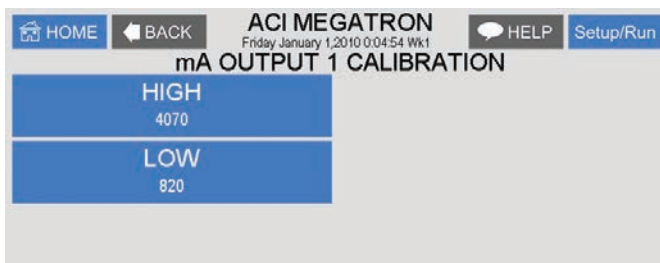

The number displayed in the Calibration dialog box can range from 0-4,095, with 800 equal to 0 mA output, and 4,030 equal to 20 mA. This number range of 0-4,095 is the raw digital-to-analog (D/A) values and is strictly used for reference. The D/A numbers that you get will vary based on your installation conditions.

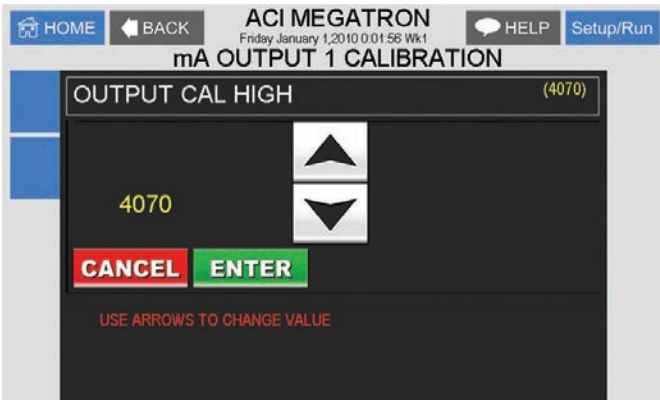

While in the High or Low calibration pop-up screen use the up and down arrows to change the output value being read with the voltmeter. Adjust the High value for the 20-mA reading and the Low value for the 4-mA value.

### 3.4 4-20mA Input Calibration

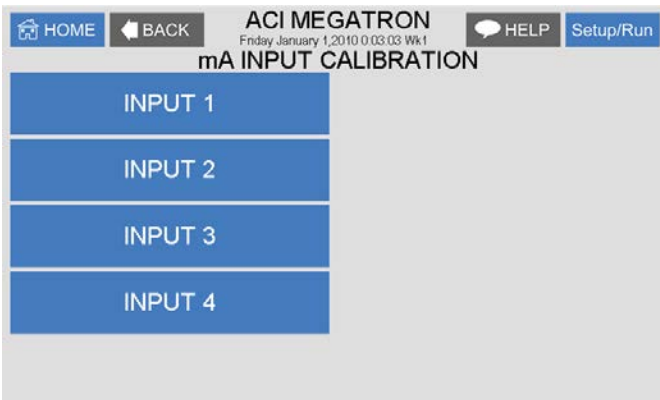

4-20mA inputs can be calibrated to ensure that the input seen by the controller from the external device match. It also allows for setting the 4-20mA input into a number range that relates to the value being read.

Select the Input to be calibrated.

Firmware version XT.16.03 and newer have logic that suspends any control logic if the mA received is 50% below the stored 4mA value. A # will be placed in the RUN screen for any mA value in this invalid state.

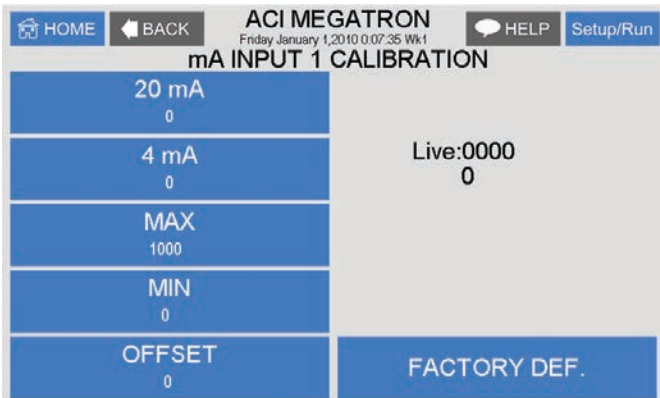

The **20mA** and **4mA** values are where the controller's raw analog to digital value is adjusted to match a 20mA (full scale) and 4mA (bottom of scale) signal from the external device inputting the 4-20mA input. The external device must be connected to the controller and showing either full or bottom of scale when calibrating each. The number shown along with either the 20mA or 4mA while calibrating is the raw A/D value, and is only a reference. A 20mA input should be around 5,500, and 4mA around 1,100. If the A/D numbers are not in this range, check the input device.

If a mA Input is receiving an A/D value 50% below the stored value for 4mA, the reading is viewed as invalid, and control logic is suspended. This is represented on the RUN screen with a #.

The **MAX** and **LOW** calibration inputs define what to display for a 20mA input and a 4mA input. For a drum level sensor on a 55-gallon drum, the value for **MAX** should be 55 and **MIN** should be 0. A number is automatically displayed between 55 and 0 based on the input value. The scale and units of measure (gallons for example) are set in the Customize menu from the Home page. If the decimal position is changed in Customize, all mA input settings and **MIN/MAX** will need to be reset.

**OFFSET** - Changes the current displayed value of the 4-20mA input reading to allow for a manual 1pt calibration of the displayed value.

**FACTORY DEFAULT** - If the 20mA or 4mA calibration has been incorrectly set (not at 4 or 20) this will reset the settings back to a factory value for 4 and 20.

## 4. Customize

This menu allows the user to define the on-screen name of the unit plus the name of each system and relay. The user can also set up the Notepad for each system and 4-20mA Input's name and unit of measurement.

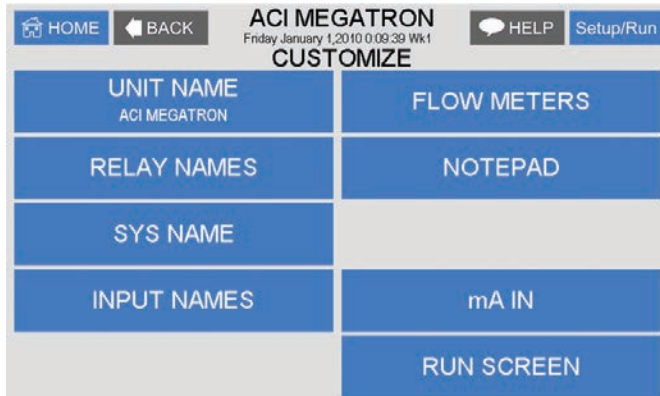

**RUN SCREEN** - Allows the user to select what will be shown on the screen while the controller is in the RUN mode, such as displaying temperature readings, water meter totals for a particular system, or the conductivity units of measure.

**NOTE:** When entering values for custom names use the numerical keys for numbers and the up / down arrows to scroll through all the characters of a keyboard. Press the right arrow to advance the cursor after setting a desired value. Press the Help button to place the last entered character into the new cursor space to speed up the process. The Help button will also jump advance through the characters.

### 4.1 Notepad

The Notepad function allows the user to set up and store manually entered data or perform simple calculations between two different sensor or notepad inputs. There are ten notepad fields per system card and each can be given a custom name, UOM and number range.

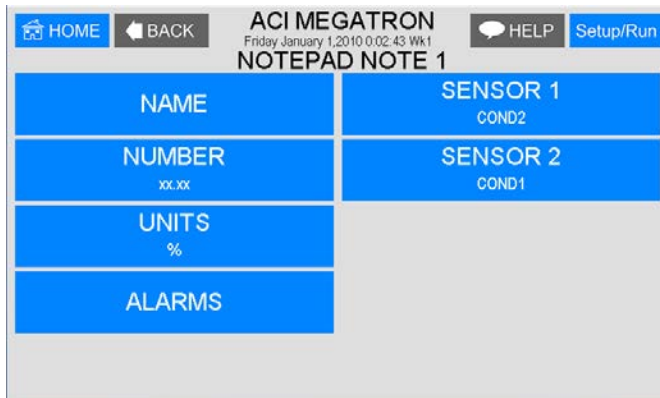

**NAME** - Pick from a list of defined names or customize your own or if you want the Notepad to be a Calculation.  
**NUMBER** - Set the number range.  
**UNITS** - Set the units of measurement.  
**ALARMS** - Set Hi/Low alarm points and how frequently a new value is expected to be manually entered via the History menu.

If the Notepad is a calculation no time alarm is defined and the calculation results are stored in history at the time stamp interval.

**CALCULATION** - If a Notepad is to be a calculation select the type of calculation desired.

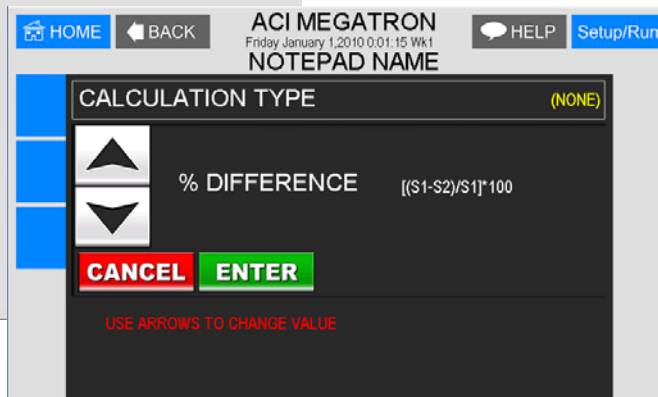
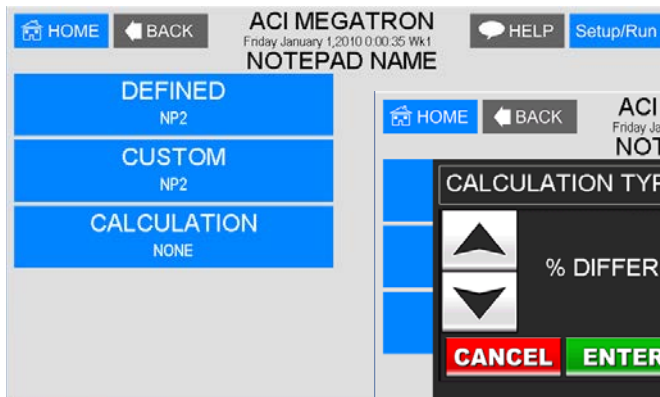

#### Calculation Types:

- None
- % Increase
- Product
- Total
- Ratio
- % Difference
- Difference

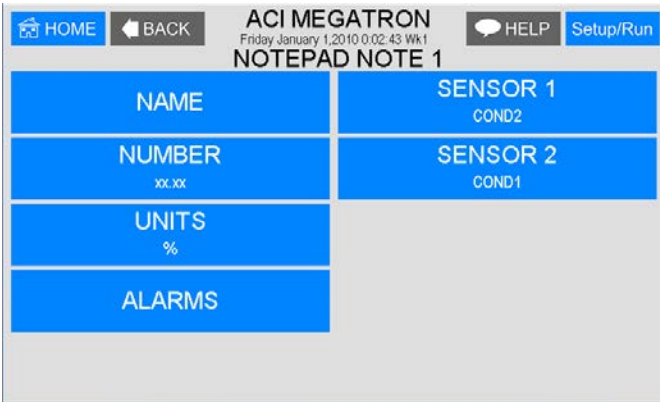

**SENSOR 1** - The first sensor reading or Notepad value to be used in the calculation.

**SENSOR 2** - The second sensor reading or Notepad value to be used in the calculation.

## 4.2 mA Inputs

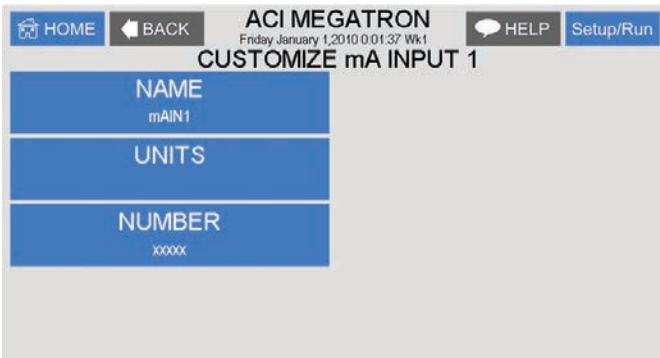

**NAME** - Name the input.

**UNITS** - Set the units of measurement.

**NUMBER** - Set the number range.

## 4.3 Run Screen

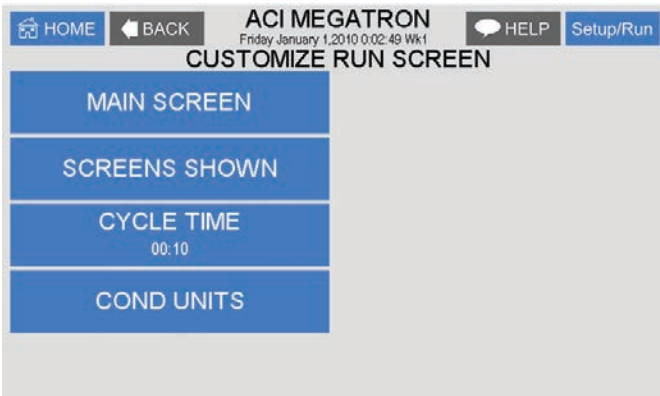

This lets you customize various aspects of the RUN screen.

**MAIN SCREEN** - Customize what is displayed on the RUN screen.

**SCREENS SHOWN** - Pick if the mA input & Aux Flow screens are scrolled.

**CYCLE TIME** - The amount of time between screen scrolls.

**COND UNITS** - Select the units of measure to be displayed with the conductivity reading.

## 5. Configure

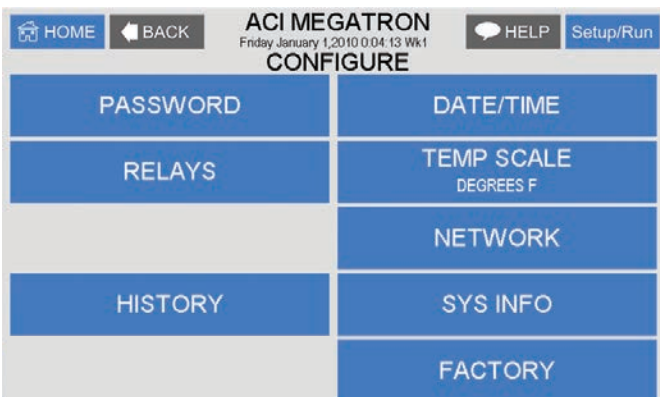

Provides access to menus to set-up passwords, relay activation, temp scale, display contrast, flow switch, inputs, history time stamps, factory set-up and system information.

**FACTORY** - A factory only menu

**TEMP SCALE** - Set Celsius or Fahrenheit

**HISTORY** - Sets the history time stamp interval.

**SYS INFO** - Tells unit software specifics.

## 5.1 Password

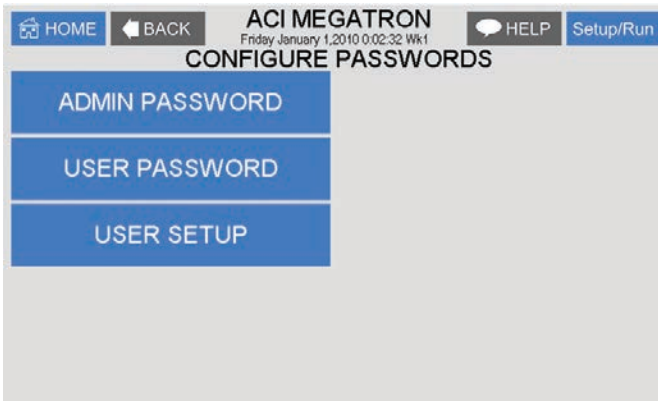

**ADMIN PASSWORD** - The administrator password gives access to all menus except factory set up.

**USER PASSWORD** - The user password allows the user to access HOME menus that are made available in USER SET UP.

## 5.2 Date and Time Set Up

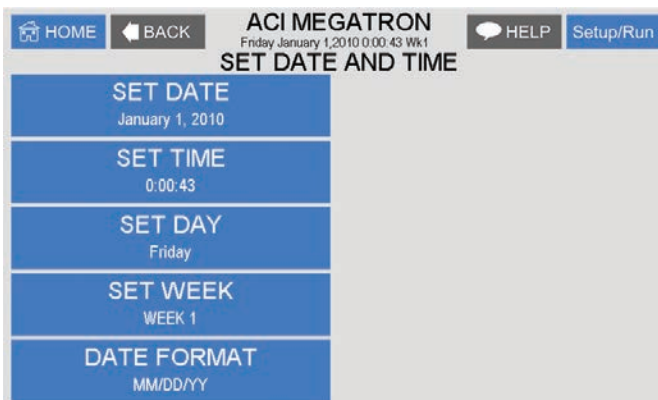

**DATE AND TIME** - For setting the date, time, day, and week on the controller.

## 5.3 Relays

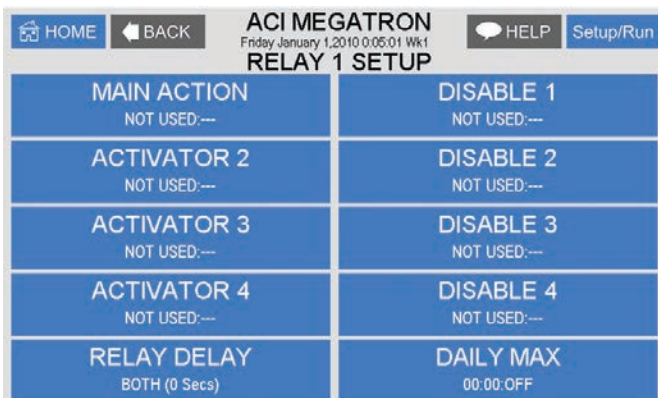

**CONFIGURE RELAYS** - This menu lets you choose a **Main Action** or function (timer 1, conductivity, alarms etc...) to activate a relay.

A pop-up screen appears with a list of all available activation functions to arrow through.

Additional relay logic is available with up to 3 additional **Activators** and up to 4 **Disablers** allowing multiple functions to activate the same relay and multiple functions to prevent the relay from coming on. There is also a Daily Max amount of time that a relay can be on. If a relay is on for the max amount, it does not let the relay come on anymore that day (a 24-hour clock is used for the day with midnight being the start of the day). The Delay setting is the amount of time a control function must come on before the relay will react and activate. This is to prevent a relay from chattering on/off if a reading is bouncing around the set point or alarm.

## 5.4 History

This menu is used to set the history “time stamp” interval, the water meter daily history starting hour, the alarm delay period and the USB history save format.

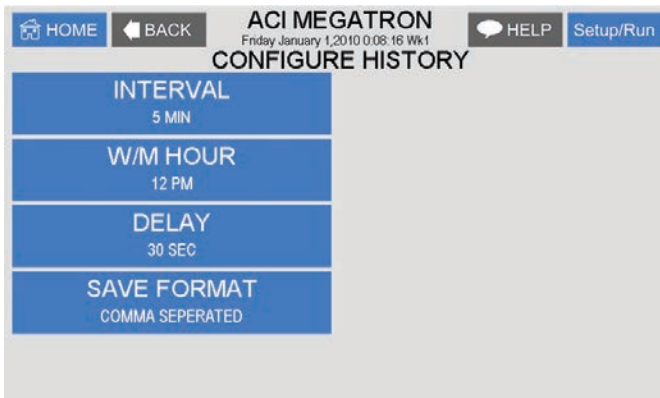

**INTERVAL** - The amount of time between each history time stamp for probe readings.

**W/M HOUR** - The time of day that the daily water meter history cycle is to start.

**ALARM DELAY** - The amount of time an alarm has to be on before it is recognized as an alarm.

**SAVE FORMAT** - The USB history save format.

## 5.5 Network

The Network menu is used when a controller is being remotely communicated with either a local network connection or over the internet on the WebAdvantage server. IP Address, IP Mask, Gateway, and other information can be viewed from this menu.

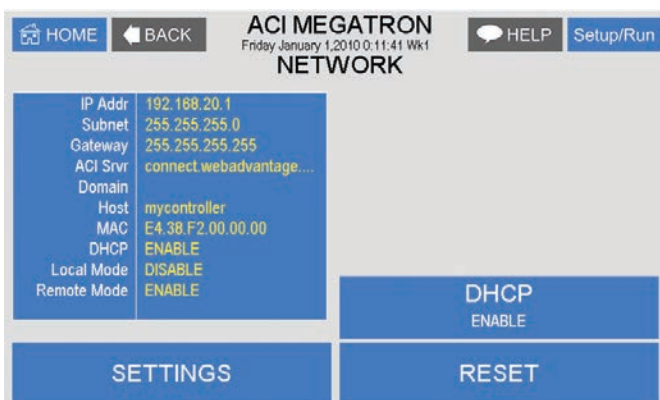

**SETTINGS** - This menu is used for setting up the remote WebAdvantage communications and is covered in a separate manual.

<http://www.advantagecontrols.com/downloads/pdf/M-WebAdvantage.pdf>

**Note:** The Network card must be RESET after making any changes to Network setting in order to save changes and reset communications.

## 5.6 System Information

System information will identify the version of firmware installed in the controller along with the controller’s serial number.

## 6. History

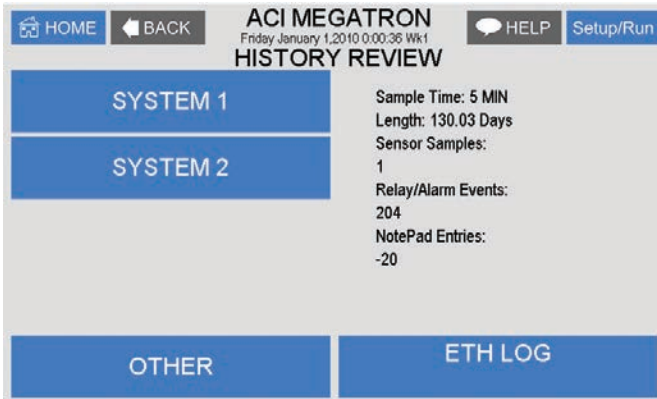

The onboard history allows for viewing the history of the probe readings, relay activations, key-pad activity, calibrations, water meter hourly and daily logs, and alarms for each system present. It is also where Notepad data is entered and reviewed. An initial overview page is displayed showing your current sample interval, the calculated number of days the unit can keep probe history for before losing the oldest. The number of sensor samples and relay/alarm events and Notepad entries currently stored is also displayed.

**NOTE:** The history can be reset by going to the configure menu and entering a different sample interval. After the new sample interval has been set, the onboard history is reset.

### 6.1 Viewing History

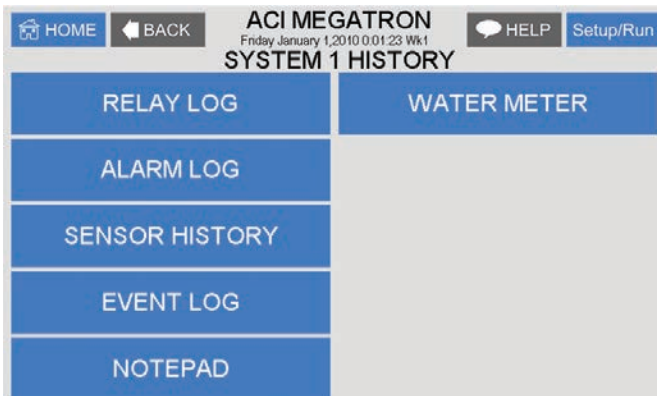

**RELAY LOGS** - Relay activations displayed in a log form. Arrow up to advance through the log.

**ALARM LOG** - Alarm activations in log form. **SENSOR HISTORY** - For selecting the parameters and viewing of a given probe reading's history in log or graph form.

**EVENT LOG** - Displays various activities.

### 6.2 Notepad Entries

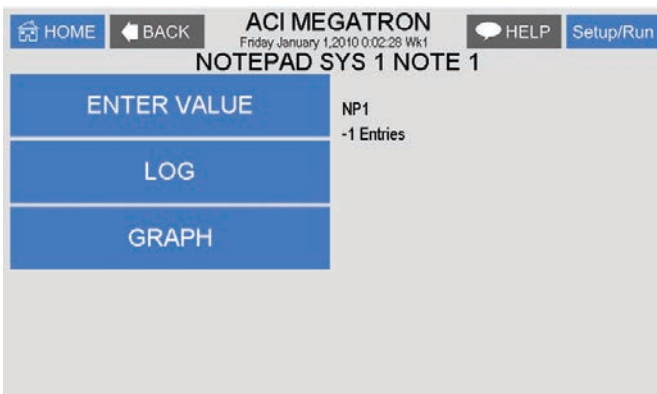

The Notepad section under History is where the user goes to enter new values for the customized notepad items. Each individual notepad item's manually entered entries are stored in the unit's history and can be reviewed in log or graph form after 4 or more values have been entered.

### 6.3 Water Meter History

The water meter history allows the user to review both water meter one and two of a particular system in both an hourly format (for the past 24 hours) or a daily format for the past 60 days. If an evaporation calculation is being kept, a daily history of this value is also available.

## 7. Flow Meters

ACI MEGATRON Friday January 1, 2010 0:03:27 Wk1 FLOW METER	
FLOW METER 1	FLOW METER 6
FLOW METER 2	FLOW METER 7
FLOW METER 3	FLOW METER 8
FLOW METER 4	FLOW METER 9
FLOW METER 5	FLOW METER 10

A unit may have up to 10 option auxiliary flow meter inputs. These additional inputs are for tracking various flow meter devices like Advantage Controls' FloTracker in a metering pump's discharge tubing. They can also be linked to a system's water meter input for additional tracking and alarm capabilities.

Select the Aux Flow Meter to set-up or review.

### 7.1 Flow Meter Setup

The Flow Meter setup gives the user access to the various settings for the flow meter along with a review of the current settings.

ACI MEGATRON Friday January 1, 2010 0:03:48 Wk1 AUX FLOWMETER 1 SETUP	
PULSE VALUE 1.0 GAL/CONTACT	VOLUME ALARM
UNITS GAL/CONTACT	RESET VOLUME
RESET TOTAL 99999999 GALLONS	METER LINK NONE
VERIFY ALARM 10 Secs	LAST RESET ON : 00/00/001 FLOW RATE : 0000.0 GALLONS/MIN FLOW METER TOTAL : 99999999.9 GALLONS
RELAY LINK NO RELAY	TRACKING RATE & VOLUME

**PULSE VALUE** - Defines the numerical value for a contact, i.e. 225.

**UNITS** - Defines the units of measure for a contact, i.e. Pulses / Ounce.

**RESET TOTAL** - Resets the totalized count of the meter.

**VERIFY ALARM** - If a flow meter is linked to a control relay, the controller will give an alarm if it does not receive a contact or pulse from the aux meter within the amount of time defined, or if it gets a contact when the relay is not on.

**RELAY LINK** - The relay link informs the Aux meter input is relevant to the control function that the selected relay is being driven by. For example, if the Aux flow meter is a metering pump's FloTracker then it should be linked to the relay that is driven by the feed timer that pump will be controlled by. If the Aux meter is going to be linked to a water meter in a bleed-off line then it should be linked to the relay that is controlling the bleed off valve.

**VOLUME ALARM** - If FloTracker has been selected as the Tracking method, an alarm will occur when the defined VOLUME USED has passed through the flow device.

**Note:** If Rate and Volume tracking has been selected an alarm will occur if the defined MAX VOLUME amount is measured within the defined TIME CYCLE which can be a 12- or 24-hour period.

**RESET VOLUME** - Resets the Volume Alarm totalizer.

**METER LINK** – This selection only shows if the tracking method is Rate and Volume and tells the auxiliary flowmeter input to get its signals from one of the system water meters already wired to the controller's water meter inputs. If this is selected, no wiring to the auxiliary input is required and the PULSE VALUE and UNITS settings are auto populated from the water meter's settings.

**TRACKING** - Provides a pop-up screen to select either FloTracker or Rate and Volume tracking.

## 8. Relays

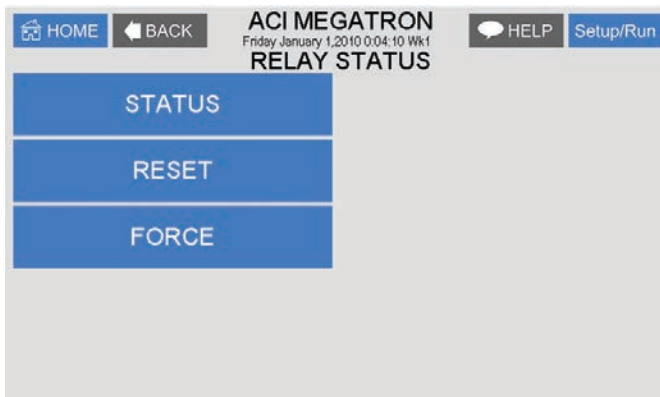

**STATUS** - Allows for viewing accumulated relay ON times, temporary forcing relays ON or OFF or seeing which relay is on.

**RESET** - Allows the accumulated run time of a particular relay to be reset to zero.

**FORCE** - Allows a relay to be manually forced ON or OFF for a single event from 0-999 minutes. When the event is over the relay goes back to its normal automatic control.

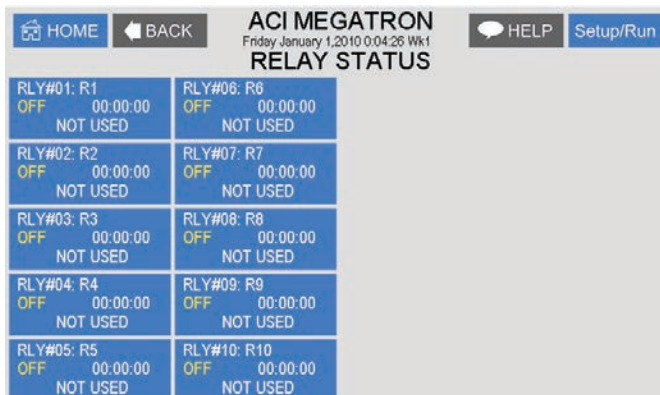

In the STATUS view the accumulated ON time is shown along with the main activator, custom name and current status:

ON = Relay on by relay activators

OFF = Relay off by normal logic

OFF-T = Relay off for daily max

OFF-D = Relay off for relay disabler

ON-A = Relay activated by activator other than main action

H-ON = Relay manually forced on

H-OFF = Relay manually forced off

## **VII. Maintenance**

The only required maintenance for normal uninterrupted operation of your MegaTronXT controller is cleaning of the electrode(s). After initial startup, it is a good idea to clean the electrode frequently until a schedule based on need has been developed. Since each application is unique, it is difficult to estimate the required frequency of cleaning. The first cleaning should take place after about one week of the system being online.

To determine the required cleaning frequency, record the reading on the controller before the electrode is removed for cleaning. After cleaning, record the new reading. If a change is observed in the two readings, the electrode was dirty. The more significant the change, the dirtier the electrode. If no change occurs, cleaning needs to be done less often.

## **VIII. Advantage Controls' Product Warranty**

Advantage Controls warrants control systems of its manufacture to be free of defects in material or workmanship. Liability under this policy extends for 24 months from the date of installation. Liability is limited to repair or replacement of any failed equipment or part proven defective in material or workmanship upon manufacturer's examination. Removal and installation costs are not included under this warranty. Manufacturer's liability shall never exceed the selling price of equipment or part in question.

Advantage disclaims all liability for damage by its products caused by improper installation, maintenance, use or attempts to operate products beyond their intended functionality, intentionally or otherwise, or any unauthorized repair. Advantage is not responsible for damages, injuries or expenses incurred through the use of its products.

The above warranty is in lieu of other warranties, either expressed or implied. No agent of ours is authorized to provide any warranty other than the above.

### **30 Day Billing Memo Policy**

Advantage Controls maintains a unique factory exchange program to ensure uninterrupted service with minimum downtime. If your controller malfunctions, call 1-918-686-6211, provide our technician with Model and Serial Number information. If they are unable to diagnose and solve your problem over the phone, a fully warranted replacement will be shipped, usually within 48 hours, on a 30-Day Billing Memo.

This service requires a purchase order, and the replacement is billed to your regular account for payment.

The replacement will be billed at the current list price for that model less any applicable resale discount. Upon return of your old panel, credit will be issued to your account at either 100% if your unit is in warranty or at 50% if your unit was out of warranty. The exchange covers only the panel. Electrode and enclosure are not included.

### **FCC Warning**

This device complies with part 15 of the FCC Rules. Operation is subject to the following two conditions: (1) This device may not cause harmful interference, and (2) this device must accept any interference received, including interference that may cause undesired operation. See 47 CFR Sec. 15.19(3).