

Ref Des	Description	Manuf/Part Number
F1	TB-5, 5x20mm,5A	Littelfuse 0234.005
F2	TB-5, 5x20mm .125A	Littelfuse 0218.125
MC1	Motor Contactor	LS GMC12M

BRANCH CIRCUIT PROTECTION
MUST BE PROVIDED EXTERNALLY
(BY CUSTOMER).

FEEDER CIRCUIT PROTECTION
MUST BE PROVIDED EXTERNALLY
(BY CUSTOMER).

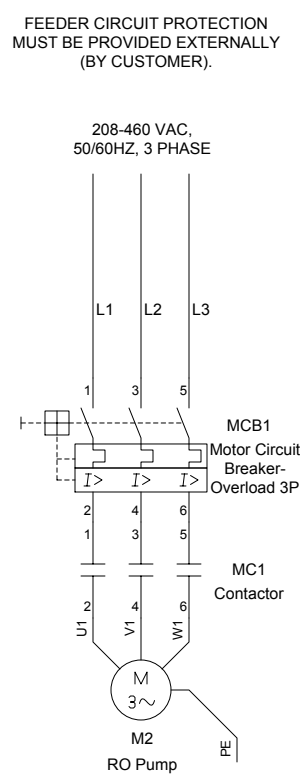

MCB-1 provides motor branch circuit protection, disconnect, motor overload, phase loss and short circuit protection. External disconnect handle available.

120/220 VAC 1P

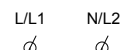

I CONTROLS
TB-5 CIRCUIT BOARD

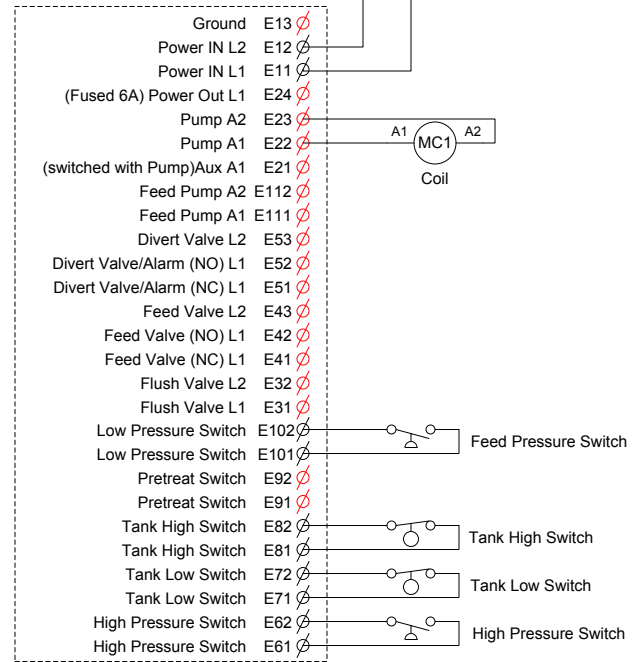

Single Tank Switch Connection

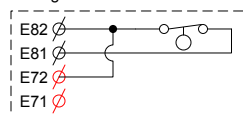

MCB1, Application Table				
Motor HP	208V	220-240V	380-415V	440-460V
1	LS MMS-32H-6	LS MMS-32H-6	LS MMS-32H-4	LS MMS-32H-2.5
1.5	LS MMS-32H-8	LS MMS-32H-8	LS MMS-32H-4	LS MMS-32H-4
2	LS MMS-32H-10	LS MMS-32H-8	LS MMS-32H-6	LS MMS-32H-4
3	LS MMS-32H-13	LS MMS-32H-13	LS MMS-32H-8	LS MMS-32H-6
5	-	-	LS MMS-32H-13	LS MMS-32H-10
7.5	-	-	LS MMS-32H-18	LS MMS-32H-13

J
I
H
G
F
E
D
C
B
A